

---

# CC3220 SimpleLink™ Wi-Fi® Wireless and Internet-of-Things Solution, a Single-Chip Wireless MCU

---

## 1 Device Overview

### 1.1 Features

- CC3220x SimpleLink™ Wi-Fi® Wireless Microcontroller Unit (MCU) System-on-Chip (SoC) is a Single-Chip With Two Separate Execution Environments: a User Application Dedicated ARM® Cortex®-M4 MCU and a Network Processor MCU to Run All Wi-Fi and Internet Logical Layers
- Chip-Level, Wi-Fi Alliance Wi-Fi CERTIFIED™
- Applications Microcontroller Subsystem
  - ARM® Cortex®-M4 Core at 80 MHz
  - Embedded Memory
    - The CC3220R and CC3220S Variants Include 256KB of RAM
    - The CC3220SF Variant is a Flash-Based Wireless MCU With Integrated 1MB of Flash and 256KB of RAM
    - External Serial Flash
  - McASP Supports Two I2S Channels
  - SD
  - SPI
  - I<sup>2</sup>C
  - UART
  - 8-Bit Parallel Camera
  - Four General-Purpose Timers With 16-Bit PWM Mode
  - Watchdog Timer
  - 4-Channel 12-Bit ADCs
  - Up to 27 GPIO Pins
  - Debug Interfaces: JTAG, cJTAG, SWD
- Wi-Fi Network Processor (NWP) Subsystem
  - Wi-Fi Internet-on-a-chip™ Dedicated ARM MCU Completely Offloads Wi-Fi and Internet Protocols from the Application MCU
  - Wi-Fi Modes:
    - 802.11b/g/n Station
    - 802.11b/g Access Point (AP) Supports up to Four Stations
    - Wi-Fi Direct® Client and Group Owner
  - WPA2 Personal and Enterprise Security: WEP, WPA/WPA2 PSK, WPA2 Enterprise (802.1x)
  - IPv4 and IPv6 TCP/IP Stack
  - Industry-Standard BSD Socket Application Programming Interfaces (APIs)
    - 16 Simultaneous TCP or UDP Sockets
    - 6 Simultaneous TLS and SSL Sockets
  - IP Addressing: Static IP, LLA, DHCPv4, DHCPv6 With DAD
  - SimpleLink Connection Manager for Autonomous and Fast Wi-Fi Connections
  - Flexible Wi-Fi Provisioning With SmartConfig™ Technology, AP Mode, and WPS2 Options
  - RESTful API Support Using the Internal HTTP Server
  - Embedded Network Applications Running on Dedicated Network Processor
  - Wide Set of Security Features:
    - Hardware Features:
      - Separate Execution Environments
      - Device Identity
      - Hardware Crypto Engine for Advanced Fast Security, Including: AES, DES, 3DES, SHA2, MD5, CRC, and Checksum
    - Initial Secure Programming:
      - Debug Security
      - JTAG and Debug Ports are Locked
    - Personal and Enterprise Wi-Fi Security
    - Secure Sockets (SSLv3, TLS1.0/1.1/TLS1.2)
  - Networking Security
    - Personal and Enterprise Wi-Fi Security
    - Secure Sockets (SSLv3, TLS1.0, TLS1.1, TLS1.2)
    - HTTPS Server
    - Trusted Root-Certificate Catalog
    - TI Root-of-Trust Public key
  - SW IP Protection
    - Secure Key Storage
    - File System Security
    - Software Tamper Detection
    - Cloning Protection
    - Secure Boot: Validate the Integrity and Authenticity of the Runtime Binary During Boot
  - Embedded Network Applications Running on the Dedicated Network Processor
    - HTTP/HTTPS Web Server With Dynamic User Callbacks
    - mDNS, DNS-SD, DHCP Server
    - Ping



- Recovery Mechanism—Can Recover to Factory Defaults or to a Complete Factory Image
  - Wi-Fi TX Power
    - 18.0 dBm @ 1 DSSS
    - 14.5 dBm @ 54 OFDM
  - Wi-Fi RX Sensitivity
    - –96 dBm @ 1 DSSS
    - –74.5 dBm @ 54 OFDM
  - Application Throughput
    - UDP: 16 Mbps
    - TCP: 13 Mbps
  - Power-Management Subsystem
    - Integrated DC-DC Converters Support a Wide Range of Supply Voltage:
      - VBAT Wide-Voltage Mode: 2.1 V to 3.6 V
      - VIO is Always Tied With VBAT
      - Preregulated 1.85-V Mode
    - Advanced Low-Power Modes
      - Shutdown: 1  $\mu$ A
      - Hibernate: 4.5  $\mu$ A
      - Low-Power Deep Sleep (LPDS): 135  $\mu$ A
  - Clock Source
    - 40.0-MHz Crystal With Internal Oscillator
    - 32.768-kHz Crystal or External RTC
  - RGK Package
    - 64-Pin, 9-mm  $\times$  9-mm Very Thin Quad Flat Nonlead (VQFN) Package, 0.5-mm Pitch
  - Operating Temperature
    - Ambient Temperature Range: –40°C to +85°C
  - Device Supports SimpleLink Developers Ecosystem
- (Measured on CC3220R, CC3220S, and CC3220SF With 256-KB RAM Retention)
- RX Traffic (MCU Active): 59 mA (Measured on CC3220R and CC3220S; CC3220SF Consumes an Additional 10 mA) @ 54 OFDM
  - TX Traffic (MCU Active): 223 mA (Measured on CC3220R and CC3220S; CC3220SF Consumes an Additional 15 mA) @ 54 OFDM, Maximum Power
  - Idle Connected (MCU in LPDS): 710  $\mu$ A (Measured on CC3220R and CC3220S With 256-KB RAM Retention) @ DTIM = 1

## 1.2 Applications

- For Internet-of-Things (IoT) applications, such as:
  - Cloud Connectivity
  - Internet Gateway
  - Home and Building Automation
  - Appliances
  - Access Control
  - Security Systems
  - Smart Energy
  - Industrial Control
  - Smart Plug and Metering
  - Wireless Audio
  - IP Network Sensor Nodes
  - Asset Tracking
  - Medical Devices

## 1.3 Description

The CC3220x device is part of the SimpleLink™ microcontroller (MCU) platform which consists of Wi-Fi, Bluetooth® low energy, Sub-1 GHz and host MCUs, which all share a common, easy-to-use development environment with a single core software development kit (SDK) and rich tool set. A one-time integration of the SimpleLink platform enables you to add any combination of the portfolio's devices into your design, allowing 100 percent code reuse when your design requirements change. For more information, visit [Overview for SimpleLink™ solutions](#).

Start your Internet-of-Things (IoT) design with a Wi-Fi® CERTIFIED® single-chip MCU System-on-Chip (SoC) with built-in Wi-Fi connectivity. Created for the IoT, the SimpleLink™ CC3220x device family from Texas Instruments™ is a single-chip solution, integrating two physically separated, on-chip MCUs.

- An application processor – ARM® Cortex®-M4 MCU with a user-dedicated 256KB of RAM, and an optional 1MB of XIP flash.
- A network processor MCU to run all Wi-Fi and Internet logical layers. This ROM-based subsystem includes an 802.11b/g/n radio, baseband, and MAC with a powerful crypto engine for fast, secure internet connections with 256-bit encryption.

The CC3220x wireless MCU family is part of the second generation of TI's Internet-on-a-chip™ family of solutions. This generation introduces new features and capabilities that further simplify the connectivity of things to the Internet. The new capabilities including the following:

IPv6

- Enhanced Wi-Fi provisioning
- Enhanced power consumption
- Enhanced file system security (supported only by the CC3220S and CC3220SF devices)
- Wi-Fi AP connection with up to four stations
- More concurrently opened BSD sockets; up to 16 BSD sockets, of which 6 are secure
- HTTPS support
- RESTful API support
- Asymmetric keys crypto library

The CC3220x wireless MCU family supports the following modes: station, AP, and Wi-Fi Direct<sup>®</sup>. The device also supports WPA2 personal and enterprise security. This subsystem includes embedded TCP/IP and TLS/SSL stacks, HTTP server, and multiple Internet protocols. The device supports a variety of Wi-Fi provisioning methods including HTTP based on AP mode, SmartConfig<sup>™</sup> Technology, and WPS2.0.

The power-management subsystem includes integrated DC-DC converters that support a wide range of supply voltages. This subsystem enables low-power consumption modes for extended battery life, such as low-power deep sleep, hibernate with RTC (consuming only 4.5  $\mu$ A), and shutdown mode (consuming only 1  $\mu$ A).

The device includes a wide variety of peripherals, including a fast parallel camera interface, I2S, SD, UART, SPI, I<sup>2</sup>C, and 4-channel ADC.

The SimpleLink CC3220x device family comes in three different device variants: CC3220R, CC3220S, and CC3220SF.

The CC3220R and CC3220S devices include 256KB of application-dedicated embedded RAM for code and data, ROM with external serial flash bootloader, and peripheral drivers.

The CC3220SF device includes application-dedicated 1MB of XIP flash and 256KB of RAM for code and data, ROM with external serial flash bootloader, and peripheral drivers. The CC3220S and CC3220SF device options have additional security features, such as encrypted and authenticated file systems, user IP encryption and authentication, secured boot (authentication and integrity validation of the application image at flash and boot time), and more.

The CC3220x device family is a complete platform solution including software, sample applications, tools, user and programming guides, reference designs, and the E2E<sup>™</sup> online community. The device family is also part of the SimpleLink MCU portfolio and supports the SimpleLink developers ecosystem.

#### Device Information<sup>(1)</sup>

PART NUMBER	PACKAGE	BODY SIZE
CC3220RM2ARGKR/T	VQFN (64)	9.00 mm x 9.00 mm
CC3220SM2ARGKR/T	VQFN (64)	9.00 mm x 9.00 mm
CC3220SF12ARGKR/T	VQFN (64)	9.00 mm x 9.00 mm

(1) For all available packages, see the orderable addendum at the end of the data sheet.

## 1.4 Functional Block Diagrams

Figure 1-1 shows the CC3220x hardware overview.

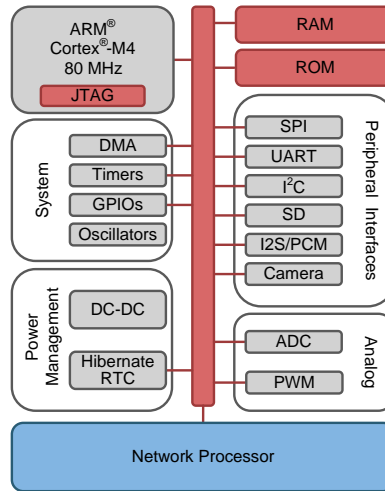

Copyright © 2017, Texas Instruments Incorporated

**Figure 1-1. CC3220x Hardware Overview**

Figure 1-2 shows an overview of the CC3220x embedded software.

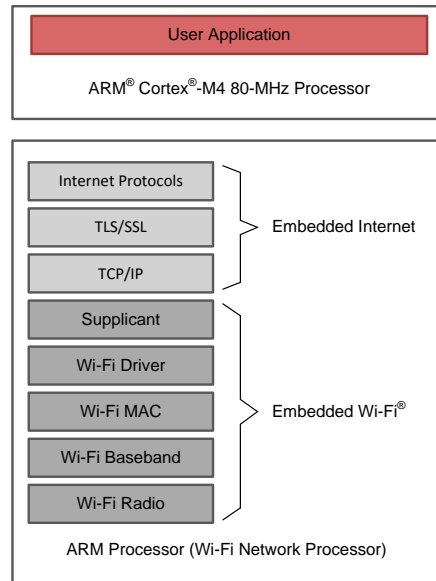

Copyright © 2017, Texas Instruments Incorporated

**Figure 1-2. CC3220x Embedded Software Overview**

## Table of Contents

<b>1 Device Overview</b> .....	<b>1</b>	4.13 Thermal Resistance Characteristics for RGK Package .....	34
1.1 Features .....	1	4.14 Timing and Switching Characteristics .....	34
1.2 Applications .....	2	<b>5 Detailed Description</b> .....	<b>51</b>
1.3 Description .....	2	5.1 Overview .....	51
1.4 Functional Block Diagrams .....	4	5.2 Functional Block Diagram .....	51
<b>2 Revision History</b> .....	<b>5</b>	5.3 ARM® Cortex®-M4 Processor Core Subsystem ....	52
<b>3 Terminal Configuration and Functions</b> .....	<b>6</b>	5.4 Wi-Fi Network Processor Subsystem .....	52
3.1 Pin Diagram .....	6	5.5 Security .....	55
3.2 Pin Attributes and Pin Multiplexing .....	7	5.6 Power-Management Subsystem .....	58
3.3 Drive Strength and Reset States for Analog and Digital Multiplexed Pins .....	23	5.7 Low-Power Operating Mode .....	59
3.4 Pad State After Application of Power To Chip But Before Reset Release .....	23	5.8 Memory .....	61
3.5 Connections for Unused Pins .....	24	5.9 Restoring Factory Default Configuration .....	64
<b>4 Specifications</b> .....	<b>25</b>	5.10 Boot Modes .....	64
4.1 Absolute Maximum Ratings .....	25	<b>6 Applications, Implementation, and Layout</b> .....	<b>66</b>
4.2 ESD Ratings .....	25	6.1 Application Information .....	66
4.3 Power-On Hours .....	25	6.2 PCB Layout Guidelines .....	71
4.4 Recommended Operating Conditions .....	25	<b>7 Device and Documentation Support</b> .....	<b>74</b>
4.5 Current Consumption Summary (CC3220R, CC3220S) .....	26	7.1 Tools and Software .....	74
4.6 Current Consumption Summary (CC3200SF) .....	27	7.2 Device Nomenclature .....	75
4.7 TX Power and IBAT versus TX Power Level Settings .....	28	7.3 Documentation Support .....	75
4.8 Brownout and Blackout Conditions .....	30	7.4 Community Resources .....	77
4.9 Electrical Characteristics (3.3 V, 25°C) .....	31	7.5 Trademarks .....	78
4.10 WLAN Receiver Characteristics .....	33	7.6 Electrostatic Discharge Caution .....	78
4.11 WLAN Transmitter Characteristics .....	33	7.7 Export Control Notice .....	78
4.12 WLAN Filter Requirements .....	34	7.8 Glossary .....	78
		<b>8 Mechanical, Packaging, and Orderable Information</b> .....	<b>79</b>

## 2 Revision History

NOTE: Page numbers for previous revisions may differ from page numbers in the current version.

Changes from September 28, 2016 to February 8, 2017	Page
• Changed the orderable part numbers in <i>Device Information</i> table .....	3
• Changed RF pins UNIT to dB .....	25
• Added test conditions to $V_{OH}$ and $V_{OL}$ rows of <a href="#">Section 4.9</a> .....	31
• Changed "timing parameters" to "electrical specifications" .....	47
• Changed note from "Corrected through firmware" to "Offset error < 1 LSB. TI recommends using the ADC API functions, which automatically compensate for offset error." .....	47
• Added note on GPIO_26 and GPIO_27 .....	67
• Added <a href="#">Table 6-1</a> .....	68
• Added <a href="#">Figure 6-2</a> .....	69
• Added <a href="#">Table 6-2</a> .....	70

### 3 Terminal Configuration and Functions

#### 3.1 Pin Diagram

Figure 3-1 shows pin assignments for the 64-pin VQFN package.

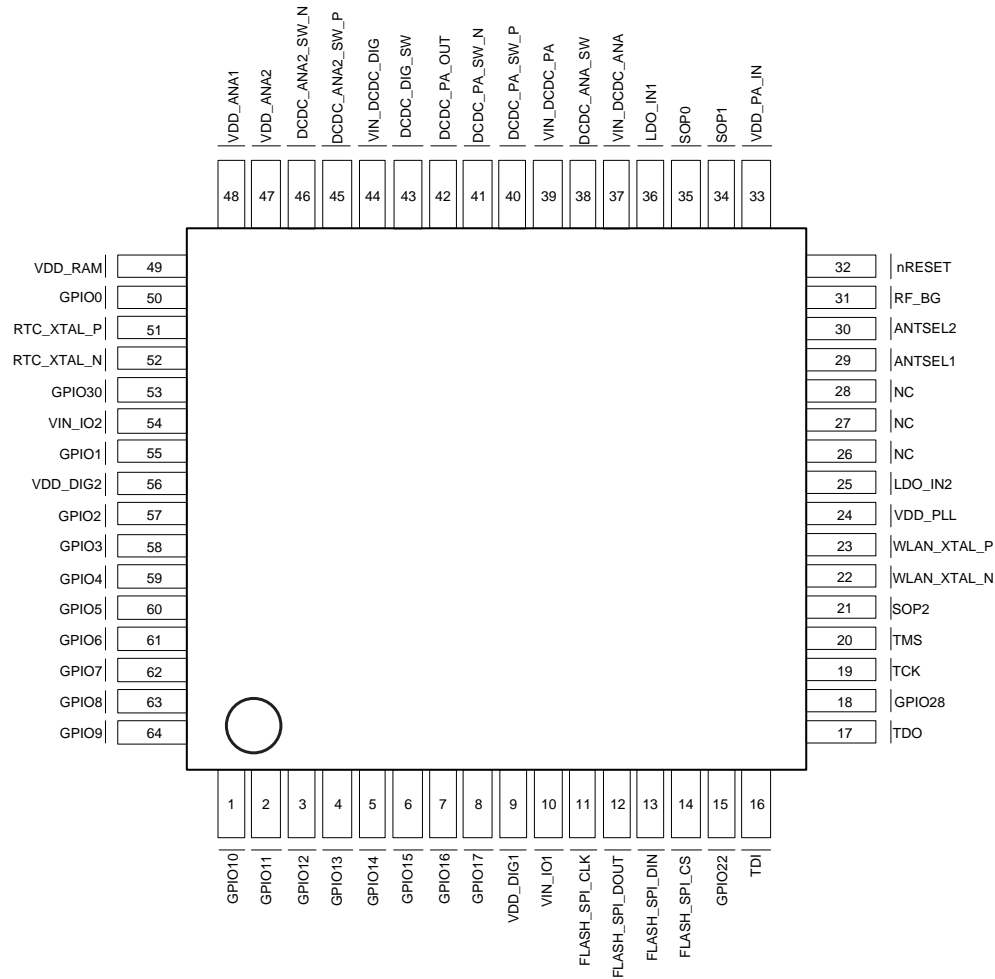

Figure 3-1. VQFN 64-Pin Assignments Top View

## 3.2 Pin Attributes and Pin Multiplexing

The device makes extensive use of pin multiplexing to accommodate the large number of peripheral functions in the smallest possible package. To achieve this configuration, pin multiplexing is controlled using a combination of hardware configuration (at device reset) and register control.

---

### NOTE

TI highly recommends using [Pin Mux Tool](#) to obtain the desired pinout.

---

The board and software designers are responsible for the proper pin multiplexing configuration. Hardware does not ensure that the proper pin multiplexing options are selected for the peripherals or interface mode used.

[Table 3-1](#) describes the general pin attributes and presents an overall view of pin multiplexing. All pin multiplexing options are configurable using the pin mux registers.

The following special considerations apply:

- All I/Os support drive strengths of 2, 4, and 6 mA. The drive strength is individually configurable for each pin.
  - All I/Os support 10- $\mu$ A pullups and pulldowns.
  - The VIO and VBAT supply must be tied together at all times.
  - All digital I/Os are nonfail-safe.
- 

### NOTE

If an external device drives a positive voltage to the signal pads and the CC3220x device is not powered, DC is drawn from the other device. If the drive strength of the external device is adequate, an unintentional wakeup and boot of the CC3220x device can occur. To prevent current draw, TI recommends any one of the following conditions:

- All devices interfaced to the CC3220x device must be powered from the same power rail as the chip.
  - Use level shifters between the device and any external devices fed from other independent rails.
  - The nRESET pin of the CC3220x device must be held low until the VBAT supply to the device is driven and stable.
  - All GPIO pins default to mode 0 unless programmed by the MCU. The bootloader sets the TDI, TDO, TCK, TMS, and Flash\_SPI pins to mode 1. All the other pins are left in the Hi-Z state.
-

Table 3-1. Pin Attributes and Pin Multiplexing

GENERAL PIN ATTRIBUTES						FUNCTION					PAD STATES		
Pkg. Pin	Pin Alias	Use	Select as Wakeup Source	Config. Addl. Analog Mux	Muxed With JTAG	Dig. Pin Mux Config. Reg.	Dig. Pin Mux Config. Mode Value	Signal Name	Signal Description	Signal Direction	LPDS <sup>(1)</sup>	Hib <sup>(2)</sup>	nRESET = 0
1	GPIO10	I/O	No	No	No	GPIO_PAD_CONFIG_10 (0x4402 E0C8)	0	GPIO10	GPIO	I/O	Hi-Z, Pull, Drive	Hi-Z, Pull, Drive	Hi-Z
							1	I2C_SCL	I <sup>2</sup> C clock	I/O (open drain)	Hi-Z, Pull, Drive		
							3	GT_PWM06	Pulse-width modulated O/P	O	Hi-Z, Pull, Drive		
							7	UART1_TX	UART TX data	O	1		
							6	SDCARD_CLK	SD card clock	O	0		
							12	GT_CCP01	Timer capture port	I	Hi-Z, Pull, Drive		

**Table 3-1. Pin Attributes and Pin Multiplexing (continued)**

GENERAL PIN ATTRIBUTES						FUNCTION					PAD STATES		
Pkg. Pin	Pin Alias	Use	Select as Wakeup Source	Config. Addl. Analog Mux	Muxed With JTAG	Dig. Pin Mux Config. Reg.	Dig. Pin Mux Config. Mode Value	Signal Name	Signal Description	Signal Direction	LPDS <sup>(1)</sup>	Hib <sup>(2)</sup>	nRESET = 0
2	GPIO11	I/O	Yes	No	No	GPIO_PAD_CONFIG_11 (0x4402 E0CC)	0	GPIO11	GPIO	I/O	Hi-Z, Pull, Drive	Hi-Z, Pull, Drive	Hi-Z
							1	I2C_SDA	I <sup>2</sup> C data	I/O (open drain)	Hi-Z, Pull, Drive		
							3	GT_PWM07	Pulse-width modulated O/P	O	Hi-Z, Pull, Drive		
							4	pXCLK (XVCLK)	Free clock to parallel camera	O	0		
							6	SDCARD_CMD	SD card command line	I/O (open drain)	Hi-Z, Pull, Drive		
							7	UART1_RX	UART RX data	I	Hi-Z, Pull, Drive		
							12	GT_CCP02	Timer capture port	I	Hi-Z, Pull, Drive		
							13	MCAFSX	I2S audio port frame sync	O	Hi-Z, Pull, Drive		

Table 3-1. Pin Attributes and Pin Multiplexing (continued)

GENERAL PIN ATTRIBUTES						FUNCTION					PAD STATES		
Pkg. Pin	Pin Alias	Use	Select as Wakeup Source	Config. Addl. Analog Mux	Muxed With JTAG	Dig. Pin Mux Config. Reg.	Dig. Pin Mux Config. Mode Value	Signal Name	Signal Description	Signal Direction	LPDS <sup>(1)</sup>	Hib <sup>(2)</sup>	nRESET = 0
3	GPIO12	I/O	No	No	No	GPIO_PAD_CONFIG_12 (0x4402 E0D0)	0	GPIO12	GPIO	I/O	Hi-Z, Pull, Drive	Hi-Z, Pull, Drive	Hi-Z
							3	McACLK	I2S audio port clock output	O	Hi-Z, Pull, Drive		
							4	pVS (VSYNC)	Parallel camera vertical sync	I	Hi-Z, Pull, Drive		
							5	I2C_SCL	I <sup>2</sup> C clock	I/O (open drain)	Hi-Z, Pull, Drive		
							7	UART0_TX	UART0 TX data	O	1		
							12	GT_CCP03	Timer capture port	I	Hi-Z, Pull, Drive		
4	GPIO13	I/O	Yes	No	No	GPIO_PAD_CONFIG_13 (0x4402 E0D4)	0	GPIO13	GPIO	I/O	Hi-Z, Pull, Drive	Hi-Z, Pull, Drive	Hi-Z
							5	I2C_SDA	I <sup>2</sup> C data	I/O (open drain)			
							4	pHS (HSYNC)	Parallel camera horizontal sync	I			
							7	UART0_RX	UART0 RX data	I			
							12	GT_CCP04	Timer capture port	I			
5	GPIO14	I/O	No	No	No	GPIO_PAD_CONFIG_14 (0x4402 E0D8)	0	GPIO14	GPIO	I/O	Hi-Z, Pull, Drive	Hi-Z, Pull, Drive	Hi-Z
							5	I2C_SCL	I <sup>2</sup> C clock	I/O (open drain)			
							7	GSPI_CLK	General SPI clock	I/O			
							4	pDATA8 (CAM_D4)	Parallel camera data bit 4	I			
							12	GT_CCP05	Timer capture port	I			

**Table 3-1. Pin Attributes and Pin Multiplexing (continued)**

GENERAL PIN ATTRIBUTES						FUNCTION					PAD STATES		
Pkg. Pin	Pin Alias	Use	Select as Wakeup Source	Config. Addl. Analog Mux	Muxed With JTAG	Dig. Pin Mux Config. Reg.	Dig. Pin Mux Config. Mode Value	Signal Name	Signal Description	Signal Direction	LPDS <sup>(1)</sup>	Hib <sup>(2)</sup>	nRESET = 0
6	GPIO15	I/O	No	No	No	GPIO_PAD_CONFIG_15 (0x4402 E0DC)	0	GPIO15	GPIO	I/O	Hi-Z, Pull, Drive	Hi-Z, Pull, Drive	Hi-Z
							5	I2C_SDA	I <sup>2</sup> C data	I/O (open drain)			
							7	GSPI_MISO	General SPI MISO	I/O			
							4	pDATA9 (CAM_D5)	Parallel camera data bit 5	I			
							13	GT_CCP06	Timer capture port	I			
							8	SDCARD_DATA0	SD card data	I/O			
7	GPIO16	I/O	No	No	No	GPIO_PAD_CONFIG_16 (0x4402 E0E0)	0	GPIO16	GPIO	I/O	Hi-Z, Pull, Drive	Hi-Z, Pull, Drive	Hi-Z
											Hi-Z, Pull, Drive		
											Hi-Z, Pull, Drive		
							7	GSPI_MOSI	General SPI MOSI	I/O	Hi-Z, Pull, Drive		
							4	pDATA10 (CAM_D6)	Parallel camera data bit 6	I	Hi-Z, Pull, Drive		
							5	UART1_TX	UART1 TX data	O	1		
							13	GT_CCP07	Timer capture port	I	Hi-Z, Pull, Drive		
							8	SDCARD_CLK	SD card clock	O	Zero		

Table 3-1. Pin Attributes and Pin Multiplexing (continued)

GENERAL PIN ATTRIBUTES						FUNCTION					PAD STATES		
Pkg. Pin	Pin Alias	Use	Select as Wakeup Source	Config. Addl. Analog Mux	Muxed With JTAG	Dig. Pin Mux Config. Reg.	Dig. Pin Mux Config. Mode Value	Signal Name	Signal Description	Signal Direction	LPDS <sup>(1)</sup>	Hib <sup>(2)</sup>	nRESET = 0
8	GPIO17	I/O	Yes	No	No	GPIO_PAD_CONFIG_17 (0x4402 E0E4)	0	GPIO17	GPIO	I/O	Hi-Z, Pull, Drive	Hi-Z, Pull, Drive	Hi-Z
							5	UART1_RX	UART1 RX data	I			
							7	GSPI_CS	General SPI chip select	I/O			
							4	pDATA11 (CAM_D7)	Parallel camera data bit 7	I			
							8	SDCARD_CMD	SD card command line	I/O			
9	VDD_DIG1	Int pwr	N/A	N/A	N/A	N/A	N/A	VDD_DIG1	Internal digital core voltage	N/A	N/A	N/A	N/A
10	VIN_IO1	Sup. input	N/A	N/A	N/A	N/A	N/A	VIN_IO1	Chip supply voltage (VBAT)	N/A	N/A	N/A	N/A
11	FLASH_SPI_CLK	O	N/A	N/A	N/A	N/A	N/A	FLASH_SPI_CLK	Clock to SPI serial flash (fixed default)	O	Hi-Z, Pull, Drive <sup>(3)</sup>	Hi-Z, Pull, Drive	Hi-Z
12	FLASH_SPI_DOUT	O	N/A	N/A	N/A	N/A	N/A	FLASH_SPI_DOUT	Data to SPI serial flash (fixed default)	O	Hi-Z, Pull, Drive <sup>(3)</sup>	Hi-Z, Pull, Drive	Hi-Z
13	FLASH_SPI_DIN	I	N/A	N/A	N/A	N/A	N/A	FLASH_SPI_DIN	Data from SPI serial flash (fixed default)	I	Hi-Z, Pull, Drive <sup>(3)</sup>	Hi-Z	Hi-Z
14	FLASH_SPI_CS	O	N/A	N/A	N/A	N/A	N/A	FLASH_SPI_CS	Chip select to SPI serial flash (fixed default)	O	1	Hi-Z, Pull, Drive	Hi-Z
15	GPIO22	I/O	No	No	No	GPIO_PAD_CONFIG_22 (0x4402 E0F8)	0	GPIO22	GPIO	I/O	Hi-Z, Pull, Drive	Hi-Z, Pull, Drive	Hi-Z
							7	McAFSX	I2S audio port frame sync	O			
							5	GT_CCP04	Timer capture port	I			

**Table 3-1. Pin Attributes and Pin Multiplexing (continued)**

GENERAL PIN ATTRIBUTES						FUNCTION					PAD STATES		
Pkg. Pin	Pin Alias	Use	Select as Wakeup Source	Config. Addl. Analog Mux	Muxed With JTAG	Dig. Pin Mux Config. Reg.	Dig. Pin Mux Config. Mode Value	Signal Name	Signal Description	Signal Direction	LPDS <sup>(1)</sup>	Hib <sup>(2)</sup>	nRESET = 0
16	TDI	I/O	No	No	Muxed with JTAG TDI	GPIO_PAD_CONFIG_23 (0x4402 E0FC)	1	TDI	JTAG TDI. Reset default pinout.	I	Hi-Z, Pull, Drive	Hi-Z, Pull, Drive	Hi-Z
							0	GPIO23	GPIO	I/O			
							2	UART1_TX	UART1 TX data	O	1		
							9	I2C_SCL	I2C clock	I/O (open drain)	Hi-Z, Pull, Drive		
17	TDO	I/O	Yes	No	Muxed with JTAG TDO	GPIO_PAD_CONFIG_24 (0x4402 E100)	1	TDO	JTAG TDO. Reset default pinout.	O	Hi-Z, Pull, Drive	Driven high in SWD; driven low in 4-wire JTAG	Hi-Z
							0	GPIO24	GPIO	I/O			
							5	PWM0	Pulse-width modulated O/P	O			
							2	UART1_RX	UART1 RX data	I			
							9	I2C_SDA	I <sup>2</sup> C data	I/O (open drain)			
							4	GT_CCP06	Timer capture port	I			
							6	McAFSX	I2S audio port frame sync	O			
18	GPIO28	I/O	No	No	No	GPIO_PAD_CONFIG_40 (0x4402 E140)	0	GPIO28	GPIO	I/O	Hi-Z, Pull, Drive	Hi-Z, Pull, Drive	Hi-Z
19	TCK	I/O	No	No	Muxed with JTAG/SWD-TCK	GPIO_PAD_CONFIG_28 (0x4402 E110)	1	TCK	JTAG/SWD TCK. Reset default pinout.	I	Hi-Z, Pull, Drive	Hi-Z, Pull, Drive	Hi-Z
							8	GT_PWM03	Pulse-width modulated O/P	O			
20	TMS	I/O	No	No	Muxed with JTAG/SWD-TMSC	GPIO_PAD_CONFIG_29 (0x4402 E114)	1	TMS	JTAG/SWD TMS. Reset default pinout.	I/O	Hi-Z, Pull, Drive	Hi-Z, Pull, Drive	Hi-Z
							0	GPIO29	GPIO				

Table 3-1. Pin Attributes and Pin Multiplexing (continued)

GENERAL PIN ATTRIBUTES						FUNCTION					PAD STATES		
Pkg. Pin	Pin Alias	Use	Select as Wakeup Source	Config. Addl. Analog Mux	Muxed With JTAG	Dig. Pin Mux Config. Reg.	Dig. Pin Mux Config. Mode Value	Signal Name	Signal Description	Signal Direction	LPDS <sup>(1)</sup>	Hib <sup>(2)</sup>	nRESET = 0
21 <sup>(4)</sup>	SOP2	O only	No	No	No	GPIO_PAD_CONFIG_25 (0x4402 E104)	0	GPIO25	GPIO	O	Hi-Z, Pull, Drive	Driven Low	Hi-Z
							9	GT_PWM02	Pulse-width modulated O/P	O	Hi-Z, Pull, Drive		
							2	McAFSX	I2S audio port frame sync	O	Hi-Z, Pull, Drive		
							See <sup>(5)</sup>	TCXO_EN	Enable to optional external 40-MHz TCXO	O	Zero		
							See <sup>(6)</sup>	SOP2	Sense-on-power 2	I	Hi-Z, Pull, Drive		
22	WLAN_XTAL_N	WLAN analog	N/A	N/A	N/A	N/A	See <sup>(5)</sup>	WLAN_XTAL_N	40-MHz XTAL Pulldown if external TCXO is used.	N/A	N/A	N/A	N/A
23	WLAN_XTAL_P	WLAN analog	N/A	N/A	N/A	N/A	N/A	WLAN_XTAL_P	40-MHz XTAL or TCXO clock input	N/A	N/A	N/A	N/A
24	VDD_PLL	Internal power	N/A	N/A	N/A	N/A	N/A	VDD_PLL	Internal analog voltage	N/A	N/A	N/A	N/A
25	LDO_IN2	Internal power	N/A	N/A	N/A	N/A	N/A	LDO_IN2	Analog RF supply from analog DC-DC output	N/A	N/A	N/A	N/A
26	NC	WLAN analog	N/A	N/A	N/A	N/A	N/A	NC	Reserved	N/A	N/A	N/A	N/A
27	NC	WLAN analog	N/A	N/A	N/A	N/A	N/A	NC	Reserved	N/A	N/A	N/A	N/A
28	NC	WLAN analog	N/A	N/A	N/A	N/A	N/A	NC	Reserved	N/A	N/A	N/A	N/A
29 <sup>(7)</sup>	ANTSEL1	O only	No	User config not required <sup>(8)</sup>	No	GPIO_PAD_CONFIG_26 (0x4402 E108)	0	ANTSEL1 <sup>(3)</sup>	Antenna selection control	O	Hi-Z, Pull, Drive	Hi-Z, Pull, Drive	Hi-Z

**Table 3-1. Pin Attributes and Pin Multiplexing (continued)**

GENERAL PIN ATTRIBUTES						FUNCTION					PAD STATES		
Pkg. Pin	Pin Alias	Use	Select as Wakeup Source	Config. Addl. Analog Mux	Muxed With JTAG	Dig. Pin Mux Config. Reg.	Dig. Pin Mux Config. Mode Value	Signal Name	Signal Description	Signal Direction	LPDS <sup>(1)</sup>	Hib <sup>(2)</sup>	nRESET = 0
30 <sup>(7)</sup>	ANTSEL2	O only	No	User config not required <sup>(8)</sup>	No	GPIO_PAD_CONFIG_27 (0x4402 E10C)	0	ANTSEL2 <sup>(3)</sup>	Antenna selection control	O	Hi-Z, Pull, Drive	Hi-Z, Pull, Drive	Hi-Z
31	RF_BG	WLAN analog	N/A	N/A	N/A	N/A	N/A	RF_BG	RF BG band	N/A	N/A	N/A	N/A
32	nRESET	Global reset	N/A	N/A	N/A	N/A	N/A	nRESET	Master chip reset. Active low.	N/A	N/A	N/A	N/A
33	VDD_PA_IN	Internal power	N/A	N/A	N/A	N/A	N/A	VDD_PA_IN	PA supply voltage from PA DC-DC output	N/A	N/A	N/A	N/A
34	SOP1	Config sense	N/A	N/A	N/A	N/A	N/A	SOP1	Sense-on-power 1	N/A	N/A	N/A	N/A
35	SOP0	Config sense	N/A	N/A	N/A	N/A	N/A	SOP0	Sense-on-power 0	N/A	N/A	N/A	N/A
36	LDO_IN1	Internal power	N/A	N/A	N/A	N/A	N/A	LDO_IN1	Analog RF supply from analog DC-DC output	N/A	N/A	N/A	N/A
37	VIN_DCDC_ANA	Supply input	N/A	N/A	N/A	N/A	N/A	VIN_DCDC_ANA	Analog DC-DC input (connected to chip input supply [VBAT])	N/A	N/A	N/A	N/A
38	DCDC_ANA_SW	Internal power	N/A	N/A	N/A	N/A	N/A	DCDC_ANA_SW	Analog DC-DC switching node	N/A	N/A	N/A	N/A
39	VIN_DCDC_PA	Supply input	N/A	N/A	N/A	N/A	N/A	VIN_DCDC_PA	PA DC-DC input (connected to chip input supply [VBAT])	N/A	N/A	N/A	N/A
40	DCDC_PA_SW_P	Internal power	N/A	N/A	N/A	N/A	N/A	DCDC_PA_SW_P	PA DC-DC switching node	N/A	N/A	N/A	N/A
41	DCDC_PA_SW_N	Internal power	N/A	N/A	N/A	N/A	N/A	DCDC_PA_SW_N	PA DC-DC switching node	N/A	N/A	N/A	N/A
42	DCDC_PA_OUT	Internal power	N/A	N/A	N/A	N/A	N/A	DCDC_PA_OUT	PA buck converter output	N/A	N/A	N/A	N/A
43	DCDC_DIG_SW	Internal power	N/A	N/A	N/A	N/A	N/A	DCDC_DIG_SW	Digital DC-DC switching node	N/A	N/A	N/A	N/A

Table 3-1. Pin Attributes and Pin Multiplexing (continued)

GENERAL PIN ATTRIBUTES						FUNCTION					PAD STATES		
Pkg. Pin	Pin Alias	Use	Select as Wakeup Source	Config. Addl. Analog Mux	Muxed With JTAG	Dig. Pin Mux Config. Reg.	Dig. Pin Mux Config. Mode Value	Signal Name	Signal Description	Signal Direction	LPDS <sup>(1)</sup>	Hib <sup>(2)</sup>	nRESET = 0
44	VIN_DCDC_DIG	Supply input	N/A	N/A	N/A	N/A	N/A	VIN_DCDC_DIG	Digital DC-DC input (connected to chip input supply [VBAT])	N/A	N/A	N/A	N/A
45 <sup>(9)</sup>	DCDC_ANA2_SW_P	I/O	No	User config not required <sup>(8)</sup>	No	GPIO_PAD_CONFIG_31 (0x4402 E11C)	0	GPIO31	GPIO	I/O	Hi-Z	Hi-Z	Hi-Z
							9	UART0_RX	UART0 RX data	I			
							12	McAFSX	I2S audio port frame sync	O			
							2	UART1_RX	UART1 RX data	I			
							6	McAXR0	I2S audio port data 0 (RX/TX)	I/O			
							7	GSPI_CLK	General SPI clock	I/O			
							See <sup>(5)</sup>	DCDC_ANA2_SW_P	ANA2 DCDC converter +ve switching node	N/A	N/A	N/A	
46	DCDC_ANA2_SW_N	Internal power	N/A	N/A	N/A	N/A	N/A	DCDC_ANA2_SW_N	ANA2 DC-DC converter -ve switching node	N/A	N/A	N/A	N/A
47	VDD_ANA2	Internal power	N/A	N/A	N/A	N/A	N/A	VDD_ANA2	ANA2 DC-DC output	N/A	N/A	N/A	N/A
48	VDD_ANA1	Internal power	N/A	N/A	N/A	N/A	N/A	VDD_ANA1	Analog supply fed by ANA2 DC-DC output	N/A	N/A	N/A	N/A
49	VDD_RAM	Internal power	N/A	N/A	N/A	N/A	N/A	VDD_RAM	SRAM LDO output	N/A	N/A	N/A	N/A

**Table 3-1. Pin Attributes and Pin Multiplexing (continued)**

GENERAL PIN ATTRIBUTES						FUNCTION					PAD STATES		
Pkg. Pin	Pin Alias	Use	Select as Wakeup Source	Config. Addl. Analog Mux	Muxed With JTAG	Dig. Pin Mux Config. Reg.	Dig. Pin Mux Config. Mode Value	Signal Name	Signal Description	Signal Direction	LPDS <sup>(1)</sup>	Hib <sup>(2)</sup>	nRESET = 0
50	GPIO0	I/O	No	User config not required <sup>(8)</sup>	No	GPIO_PAD_CONFIG_0 (0x4402 E0A0)	0	GPIO0	GPIO	I/O	Hi-Z, Pull, Drive	Hi-Z, Pull, Drive	Hi-Z
							12	UART0_CTS	UART0 Clear-to-Send input (active low)	I	Hi-Z, Pull, Drive		
							6	McAXR1	I2S audio port data 1 (RX/TX)	I/O	Hi-Z, Pull, Drive		
							7	GT_CCP00	Timer capture port	I	Hi-Z, Pull, Drive		
							9	GSPI_CS	General SPI chip select	I/O	Hi-Z, Pull, Drive		
							10	UART1_RTS	UART1 Request-to-Send (active low)	O	1		
							3	UART0_RTS	UART0 Request-to-Send (active low)	O	1		
							4	McAXR0	I2S audio port data 0 (RX/TX)	I/O	Hi-Z, Pull, Drive		
51	RTC_XTAL_P	RTC	N/A	N/A	N/A	N/A	N/A	RTC_XTAL_P	Connect 32.768-kHz XTAL or force external CMOS level clock	N/A	N/A	N/A	N/A

Table 3-1. Pin Attributes and Pin Multiplexing (continued)

GENERAL PIN ATTRIBUTES						FUNCTION					PAD STATES		
Pkg. Pin	Pin Alias	Use	Select as Wakeup Source	Config. Addl. Analog Mux	Muxed With JTAG	Dig. Pin Mux Config. Reg.	Dig. Pin Mux Config. Mode Value	Signal Name	Signal Description	Signal Direction	LPDS <sup>(1)</sup>	Hib <sup>(2)</sup>	nRESET = 0
52 <sup>(11)</sup>	RTC_XTAL_N	O only		User config not required <sup>(8)(10)</sup>	No	GPIO_PAD_CONFIG_32 (0x4402 E120)	N/A	RTC_XTAL_N	Connect 32.768-kHz XTAL or connect 100-kΩ resistor to V <sub>supply</sub> .	N/A	N/A	Hi-Z, Pull, Drive	Hi-Z
							0	GPIO32	GPIO	O	Hi-Z, Pull, Drive		
							2	McACLK	I2S audio port clock	O	Hi-Z, Pull, Drive		
							4	McAXR0	I2S audio port data (Only output mode supported on pin 52)	O	Hi-Z, Pull, Drive		
							6	UART0_RTS	UART0 Request-to-Send output (active low)	O	1		
							8	GSPI_MOSI	General SPI MOSI	O	Hi-Z, Pull, Drive		
53	GPIO30	I/O	No	User config not required <sup>(8)</sup>	No	GPIO_PAD_CONFIG_30 (0x4402 E118)	0	GPIO30	GPIO	I/O	Hi-Z, Pull, Drive	Hi-Z, Pull, Drive	Hi-Z
							9	UART0_TX	UART0 TX data	O	1		
							2	McACLK	I2S audio port clock	O	Hi-Z, Pull, Drive		
							3	McAFSX	I2S audio port frame sync	O	Hi-Z, Pull, Drive		
							4	GT_CCP05	Timer capture port	I	Hi-Z, Pull, Drive		
							7	GSPI_MISO	General SPI MISO	I/O	Hi-Z, Pull, Drive		

**Table 3-1. Pin Attributes and Pin Multiplexing (continued)**

GENERAL PIN ATTRIBUTES						FUNCTION					PAD STATES		
Pkg. Pin	Pin Alias	Use	Select as Wakeup Source	Config. Addl. Analog Mux	Muxed With JTAG	Dig. Pin Mux Config. Reg.	Dig. Pin Mux Config. Mode Value	Signal Name	Signal Description	Signal Direction	LPDS <sup>(1)</sup>	Hib <sup>(2)</sup>	nRESET = 0
54	VIN_IO2	Supply input	N/A	N/A	N/A	N/A	N/A	VIN_IO2	Chip supply voltage (VBAT)	N/A	N/A	N/A	N/A
55	GPIO1	I/O	No	No	No	GPIO_PAD_CONFIG_1 (0x4402 E0A4)	0	GPIO1	GPIO	I/O	Hi-Z, Pull, Drive	Hi-Z, Pull, Drive	Hi-Z
							3	UART0_TX	UART0 TX data	O	1		
							4	pCLK (PIXCLK)	Pixel clock from parallel camera sensor	I	Hi-Z, Pull, Drive		
							6	UART1_TX	UART1 TX data	O	1		
							7	GT_CCP01	Timer capture port	I	Hi-Z, Pull, Drive		
56	VDD_DIG2	Internal power	N/A	N/A	N/A	N/A	VDD_DIG2	Internal digital core voltage	N/A	N/A	N/A	N/A	
57 <sup>(13)</sup>	GPIO2	Analog input (up to 1.8 V)/ digital I/O	Wake-up source	See <sup>(12)</sup>	No	GPIO_PAD_CONFIG_2 (0x4402 E0A8)	See <sup>(5)</sup>	ADC_CH0	ADC channel 0 input (1.5-V max)	I	Hi-Z, Pull, Drive	Hi-Z, Pull, Drive	Hi-Z
							0	GPIO2	GPIO	I/O			
							3	UART0_RX	UART0 RX data	I			
							6	UART1_RX	UART1 RX data	I			
							7	GT_CCP02	Timer capture port	I			
58 <sup>(13)</sup>	GPIO3	Analog input (up to 1.8 V)/ digital I/O	No	See <sup>(12)</sup>	No	GPIO_PAD_CONFIG_3 (0x4402 E0AC)	See <sup>(5)</sup>	ADC_CH1	ADC channel 1 input (1.5-V max)	I	Hi-Z, Pull, Drive	Hi-Z, Pull, Drive	Hi-Z
							0	GPIO3	GPIO	I/O	Hi-Z, Pull, Drive		
							6	UART1_TX	UART1 TX data	O	1		
							4	pDATA7 (CAM_D3)	Parallel camera data bit 3	I	Hi-Z, Pull, Drive		

Table 3-1. Pin Attributes and Pin Multiplexing (continued)

GENERAL PIN ATTRIBUTES						FUNCTION					PAD STATES		
Pkg. Pin	Pin Alias	Use	Select as Wakeup Source	Config. Addl. Analog Mux	Muxed With JTAG	Dig. Pin Mux Config. Reg.	Dig. Pin Mux Config. Mode Value	Signal Name	Signal Description	Signal Direction	LPDS <sup>(1)</sup>	Hib <sup>(2)</sup>	nRESET = 0
59 <sup>(13)</sup>	GPIO4	Analog input (up to 1.8 V)/digital I/O	Wake-up source	See <sup>(12)</sup>	No	GPIO_PAD_CONFIG_4 (0x4402 E0B0)	See <sup>(5)</sup>	ADC_CH2	ADC channel 2 input (1.5-V max)	I	Hi-Z, Pull, Drive	Hi-Z, Pull, Drive	Hi-Z
							0	GPIO4	GPIO	I/O			
							6	UART1_RX	UART1 RX data	I			
							4	pDATA6 (CAM_D2)	Parallel camera data bit 2	I			
60 <sup>(13)</sup>	GPIO5	Analog input up to 1.5 V	No	See <sup>(12)</sup>	No	GPIO_PAD_CONFIG_5 (0x4402 E0B4)	See <sup>(5)</sup>	ADC_CH3	ADC channel 3 input (1.5 V max)	I	i-Z, Pull, Drive	Hi-Z, Pull, Drive	Hi-Z
							0	GPIO5	GPIO	I/O			
							4	pDATA5 (CAM_D1)	Parallel camera data bit 1	I			
							6	McAXR1	I2S audio port data 1 (RX, TX)	I/O			
							7	GT_CCP05	Timer capture port	I			
61	GPIO6	I/O	No	No	No	GPIO_PAD_CONFIG_6 (0x4402 E0B8)	0	GPIO6	GPIO	I/O	Hi-Z, Pull, Drive	Hi-Z, Pull, Drive	Hi-Z
							5	UART0_RTS	UART0 Request-to-Send (active low)	O	1		
							4	pDATA4 (CAM_D0)	Parallel camera data bit 0	I	Hi-Z, Pull, Drive		
							3	UART1_CTS	UART1 Clear to send (active low)	I	Hi-Z, Pull, Drive		
							6	UART0_CTS	UART0 Clear to send (active low)	I	Hi-Z, Pull, Drive		
							7	GT_CCP06	Timer capture port	I	Hi-Z, Pull, Drive		

**Table 3-1. Pin Attributes and Pin Multiplexing (continued)**

GENERAL PIN ATTRIBUTES						FUNCTION					PAD STATES		
Pkg. Pin	Pin Alias	Use	Select as Wakeup Source	Config. Addl. Analog Mux	Muxed With JTAG	Dig. Pin Mux Config. Reg.	Dig. Pin Mux Config. Mode Value	Signal Name	Signal Description	Signal Direction	LPDS <sup>(1)</sup>	Hib <sup>(2)</sup>	nRESET = 0
62	GPIO7	I/O	No	No	No	GPIO_PAD_CONFIG_7 (0x4402 E0BC)	0	GPIO7	GPIO	I/O	Hi-Z, Pull, Drive	Hi-Z, Pull, Drive	Hi-Z
							13	McACLKX	I2S audio port clock	O	Hi-Z, Pull, Drive		
							3	UART1_RTS	UART1 Request to send (active low)	O	1		
							10	UART0_RTS	UART0 Request to send (active low)	O	1		
							11	UART0_TX	UART0 TX data	O	1		
63	GPIO8	I/O	No	No	No	GPIO_PAD_CONFIG_8 (0x4402 E0C0)	0	GPIO8	GPIO	I/O	Hi-Z, Pull, Drive	Hi-Z, Pull, Drive	Hi-Z
							6	SDCARD_IRQ	Interrupt from SD card (future support)	I			
							7	McAFSX	I2S audio port frame sync	O			
							12	GT_CCP06	Timer capture port	I			
64	GPIO9	I/O	No	No	No	GPIO_PAD_CONFIG_9 (0x4402 E0C4)	0	GPIO9	GPIO	I/O	Hi-Z, Pull, Drive	Hi-Z, Pull, Drive	Hi-Z
							3	GT_PWM05	Pulse-width modulated O/P	O			
							6	SDCARD_DATA0	SD card data	I/O			
							7	McAXR0	I2S audio port data (RX, TX)	I/O			
							12	GT_CCP00	Timer capture port	I			
65	GND_TAB	GND	N/A	N/A	N/A	N/A	N/A	GND	Thermal pad and electrical ground	N/A	N/A	N/A	N/A

- (1) LPDS state: The state of unused I/Os is Hi-Z. Software may program the I/Os to be input with pull or drive (regardless of active pin configuration), according to the need.
- (2) Hibernate mode: The state of the I/Os is Hi-Z. Software may program the I/Os to be input with pull or drive (regardless of active pin configuration), according to the need.
- (3) To minimize leakage in some serial flash vendors during LPDS, TI recommends that the user application always enables internal weak pull-downs on FLASH\_SPI\_DIN, FLASH\_SPI\_DOUT, and FLASH\_SPI\_CLK pins.

- (4) This pin has dual functions: as a SOP[2] (device operation mode), and as an external TCXO enable. As a TXCO enable, the pin is an output on power up and driven logic high. During hibernate low-power mode, the pin is in a Hi-Z state but is pulled down for SOP mode to disable TCXO. Because of the SOP functionality, the pin must be used as an output only.
- (5) For details on proper use, see [Drive Strength and Reset States for Analog-Digital Multiplexed Pins](#).
- (6) This pin is one of three that must have a passive pullup or pulldown resistor onboard to configure the chip hardware power-up mode. For this reason, the pin must be output only when used for digital functions.
- (7) This pin is reserved for WLAN antenna selection, controlling an external RF switch that multiplexes the RF pin of the CC3220x device between two antennas. These pins must not be used for other functionalities.
- (8) Device firmware automatically enables the digital path during ROM boot.
- (9) Pin 45 is used by an internal DC-DC (ANA2\_DCDC). This pin will be available automatically if sFLASH is forced in the CC3220SF device. For the CC3220R and CC3220S devices, pin 45 can be used as GPIO\_31 if a supply is provided on pin 47.
- (10) To use the digital functions, RTC\_XTAL\_N must be pulled high to  $V_{\text{supply}}$  using a 100-k $\Omega$  resistor.
- (11) Pin 52 is used by the RTC XTAL oscillator. These devices use automatic configuration sensing. Therefore, some board-level configuration is required to use pin 52 as a digital pad. Pin 52 is used for RTC XTAL in most applications. However, in some applications a 32.768-kHz square-wave clock might always be available onboard. When a 32.768-kHz square-wave clock is available, the XTAL can be removed to free pin 52 for digital functions. The external clock must then be applied at pin 51. For the chip to automatically detect this configuration, a 100-k $\Omega$  pullup resistor must be connected between pin 52 and the supply line. To prevent false detection, TI recommends using pin 52 for output-only functions.
- (12) Requires user configuration to enable the analog switch of the ADC channel. (The switch is off by default.) The digital I/O is always connected and must be made Hi-Z before enabling the ADC switch.
- (13) This pin is shared by the ADC inputs and digital I/O pad cells.

---

#### NOTE

The ADC inputs are tolerant up to 1.8 V. On the other hand, the digital pads can tolerate up to 3.6 V. Hence, take care to prevent accidental damage to the ADC inputs. TI recommends first disabling the output buffers of the digital I/Os corresponding to the desired ADC channel (that is, converted to Hi-Z state), and thereafter disabling the respective pass switches (S7 [Pin 57], S8 [Pin 58], S9 [Pin 59], and S10 [Pin 60]). For more information, see [Drive Strength and Reset States for Analog-Digital Multiplexed Pins](#).

---

### 3.3 Drive Strength and Reset States for Analog and Digital Multiplexed Pins

[Table 3-2](#) describes the use, drive strength, and default state of analog and digital multiplexed pins at first-time power up and reset (nRESET pulled low).

**Table 3-2. Drive Strength and Reset States for Analog and Digital Multiplexed Pins**

Pin	Board-Level Configuration and Use	Default State at First Power Up or Forced Reset	State After Configuration of Analog Switches (ACTIVE, LPDS, and HIB Power Modes)	Maximum Effective Drive Strength (mA)
29	Connected to the enable pin of the RF switch (ANTSEL1). Other use is not recommended.	Analog is isolated. The digital I/O cell is also isolated.	Determined by the I/O state, as are other digital I/Os.	4
30	Connected to the enable pin of the RF switch (ANTSEL2). Other use is not recommended.	Analog is isolated. The digital I/O cell is also isolated.	Determined by the I/O state, as are other digital I/Os.	4
45	VDD_ANA2 (pin 47) must be shorted to the input supply rail. Otherwise, the pin is driven by the ANA2 DC-DC.	Analog is isolated. The digital I/O cell is also isolated.	Determined by the I/O state, as are other digital I/Os.	4
50	Generic I/O	Analog is isolated. The digital I/O cell is also isolated.	Determined by the I/O state, as are other digital I/Os.	4
52	The pin must have an external pullup of 100 kΩ to the supply rail and must be used in output signals only.	Analog is isolated. The digital I/O cell is also isolated.	Determined by the I/O state, as are other digital I/Os.	4
53	Generic I/O	Analog is isolated. The digital I/O cell is also isolated.	Determined by the I/O state, as are other digital I/Os.	4
57	Analog signal (1.8-V absolute, 1.46-V full scale)	ADC is isolated. The digital I/O cell is also isolated.	Determined by the I/O state, as are other digital I/Os.	4
58	Analog signal (1.8-V absolute, 1.46-V full scale)	ADC is isolated. The digital I/O cell is also isolated.	Determined by the I/O state, as are other digital I/Os.	4
59	Analog signal (1.8-V absolute, 1.46-V full scale)	ADC is isolated. The digital I/O cell is also isolated.	Determined by the I/O state, as are other digital I/Os.	4
60	Analog signal (1.8-V absolute, 1.46-V full scale)	ADC is isolated. The digital I/O cell is also isolated.	Determined by the I/O state, as are other digital I/Os.	4

### 3.4 Pad State After Application of Power To Chip But Before Reset Release

When a stable power is applied to the CC3220x chip for the first time or when supply voltage is restored to the proper value following a period with supply voltage less than 1.5 V, the level of each digital pad is undefined in the period starting from the release of nRESET and until DIG\_DCDC powers up. This period is less than approximately 10 ms. During this period, pads can be internally pulled weakly in either direction. If a certain set of pins is required to have a definite value during this prereset period, an appropriate pullup or pulldown resistor must be used at the board level. The recommended value of this external pull is 2.7 kΩ.

### 3.5 Connections for Unused Pins

All unused pins must be left as no connect (NC) pins. [Table 3-3](#) provides a list of NC pins.

**Table 3-3. Connections for Unused Pins**

PIN	DEFAULT FUNCTION	STATE AT RESET AND HIBERNATE	I/O TYPE	DESCRIPTION
26	NC	WLAN analog	–	
27	NC	WLAN analog	–	
28	NC	WLAN analog	–	

## 4 Specifications

All measurements are referenced at the device pins, unless otherwise indicated. All specifications are over process and voltage, unless otherwise indicated.

### 4.1 Absolute Maximum Ratings

over operating free-air temperature range (unless otherwise noted)

		MIN	MAX	UNIT
VBAT and VIO	Pins: 37, 39, 44	-0.5	3.8	V
VIO – VBAT (differential)	Pins: 10, 54	VBAT and VIO should be tied together		V
Digital inputs		-0.5	$V_{IO} + 0.5$	V
RF pins		-0.5	2.1	V
Analog pins, XTAL	Pins: 22, 23, 51, 52	-0.5	2.1	V
Operating temperature, $T_A$		-40	85	°C
Storage temperature, $T_{stg}$		-55	125	°C

### 4.2 ESD Ratings

		VALUE	UNIT
$V_{ESD}$ Electrostatic discharge	Human body model (HBM), per ANSI/ESDA/JEDEC JS-001 <sup>(1)</sup>	±2000	V
	Charged device model (CDM), per JEDEC specification JESD22-C101 <sup>(2)</sup>	±500	

(1) JEDEC document JEP155 states that 500-V HBM allows safe manufacturing with a standard ESD control process.

(2) JEDEC document JEP157 states that 250-V CDM allows safe manufacturing with a standard ESD control process.

### 4.3 Power-On Hours

#### NOTE

This information is provided solely for your convenience and does not extend or modify the warranty provided under TI's standard terms and conditions for TI semiconductor products.

CONDITIONS	POH
$T_A$ up to 85°C <sup>(1)</sup>	87,600

(1) The TX duty cycle (power amplifier ON time) is assumed to be 10% of the device POH. Of the remaining 90% of the time, the device can be in any other state.

### 4.4 Recommended Operating Conditions

over operating free-air temperature range (unless otherwise noted)<sup>(1)(2)</sup>

		MIN	TYP	MAX	UNIT
VBAT, VIO (shorted to VBAT)	Pins: 10, 37, 39, 44, 54	Direct battery connection <sup>(3)</sup>	2.1 <sup>(4)</sup>	3.3	V
		Preregulated 1.85 V <sup>(5)(6)</sup>		3.6	
Ambient thermal slew		-20		20	°C/minute

(1) Operating temperature is limited by crystal frequency variation.

(2) When operating at an ambient temperature of over 75°C, the transmit duty cycle must remain below 50% to avoid the auto-protect feature of the power amplifier. If the auto-protect feature triggers, the device takes a maximum of 60 seconds to restart the transmission.

(3) To ensure WLAN performance, ripple on the supply must be less than ±300 mV.

(4) The minimum voltage specified includes the ripple on the supply voltage and all other transient dips. The brownout condition is also 2.1 V, and care must be taken when operating at the minimum specified voltage.

(5) To ensure WLAN performance, ripple on the 1.85-V supply must be less than 2% (±40 mV).

(6) TI recommends keeping VBAT above 1.85 V. For lower voltages, use a boost converter.

## 4.5 Current Consumption Summary (CC3220R, CC3220S)

 $T_A = 25^\circ\text{C}$ ,  $V_{\text{BAT}} = 3.6\text{ V}$ 

PARAMETER		TEST CONDITIONS <sup>(1) (2)</sup>		MIN	TYP	MAX	UNIT
MCU ACTIVE	NWP ACTIVE	TX	1 DSSS	TX power level = 0	272		mA
				TX power level = 4	190		
			6 OFDM	TX power level = 0	248		
				TX power level = 4	182		
			54 OFDM	TX power level = 0	223		
				TX power level = 4	160		
		RX	1 DSSS	59			
54 OFDM	59						
NWP idle connected <sup>(3)</sup>				15.3			
MCU SLEEP	NWP ACTIVE	TX	1 DSSS	TX power level = 0	269		mA
				TX power level = 4	187		
			6 OFDM	TX power level = 0	245		
				TX power level = 4	179		
			54 OFDM	TX power level = 0	220		
				TX power level = 4	157		
		RX	1 DSSS	56			
54 OFDM	56						
NWP idle connected <sup>(3)</sup>				12.2			
MCU LPDS	NWP ACTIVE	TX	1 DSSS	TX power level = 0	266		mA
				TX power level = 4	184		
			6 OFDM	TX power level = 0	242		
				TX power level = 4	176		
			54 OFDM	TX power level = 0	217		
				TX power level = 4	154		
		RX	1 DSSS	53			
54 OFDM	53						
NWP LPDS <sup>(4)</sup>		120 $\mu\text{A}$ @ 64KB 135 $\mu\text{A}$ @ 256KB		135		$\mu\text{A}$	
NWP idle connected <sup>(3)</sup>				710		$\mu\text{A}$	
MCU SHUTDOWN	VBAT present and nShutdown pin pulled low				1		$\mu\text{A}$
Peak calibration current <sup>(5)</sup>	VBAT = 3.3 V				450		mA
	VBAT = 2.1 V				670		
	VBAT = 1.85 V				700		

- (1) TX power level = 0 implies maximum power (see [Figure 4-1](#), [Figure 4-2](#), and [Figure 4-3](#)). TX power level = 4 implies output power backed off approximately 4 dB.
- (2) The CC3220x system is a constant power-source system. The active current numbers scale based on the VBAT voltage supplied.
- (3) DTIM = 1
- (4) LPDS current does not include the external serial flash. The LPDS number of reported is with retention of 256KB of MCU SRAM. The CC3220x device can be configured to retain 0KB, 64KB, 128KB, 192KB, or 256KB of SRAM in LPDS. Each 64-KB block of MCU retained SRAM increases LPDS current by 4  $\mu\text{A}$ .
- (5) The complete calibration can take up to 17 mJ of energy from the battery over a time of 24 ms. In default mode, calibration is performed sparingly, and typically occurs when re-enabling the NWP and when the temperature has changed by more than 20°C. There are two additional calibration modes that may be used to reduced or completely eliminate the calibration event. For further details, see [CC3120](#), [CC3220 SimpleLink™ Wi-Fi® and IoT Network Processor Programmer's Guide](#).

## 4.6 Current Consumption Summary (CC3200SF)

 $T_A = 25^\circ\text{C}$ ,  $V_{\text{BAT}} = 3.6\text{ V}$ 

PARAMETER		TEST CONDITIONS <sup>(1)</sup> (2)		MIN	TYP	MAX	UNIT
MCU ACTIVE	NWP ACTIVE	TX	1 DSSS	TX power level = maximum		286	mA
				TX power level = maximum – 4		202	
			6 OFDM	TX power level = maximum		255	
				TX power level = maximum – 4		192	
			54 OFDM	TX power level = maximum		232	
				TX power level = maximum – 4		174	
		RX	1 DSSS		74		
54 OFDM			74				
NWP idle connected <sup>(3)</sup>					25.2		
MCU SLEEP	NWP ACTIVE	TX	1 DSSS	TX power level = maximum		282	mA
				TX power level = maximum – 4		198	
			6 OFDM	TX power level = maximum		251	
				TX power level = maximum – 4		188	
			54 OFDM	TX power level = maximum		228	
				TX power level = maximum – 4		170	
		RX	1 DSSS		70		
54 OFDM			70				
NWP idle connected <sup>(3)</sup>					21.2		
MCU LPDS	NWP active	TX	1 DSSS	TX power level = 0		266	mA
				TX power level = 4		184	
			6 OFDM	TX power level = 0		242	
				TX power level = 4		176	
			54 OFDM	TX power level = 0		217	
				TX power level = 4		154	
		RX	1 DSSS		53		
54 OFDM			53				
NWP LPDS <sup>(4)</sup>		120 $\mu\text{A}$ @ 64KB 135 $\mu\text{A}$ @ 256KB			135	$\mu\text{A}$	
NWP idle connected <sup>(3)</sup>					710	$\mu\text{A}$	
MCU SHUTDOWN	VBAT present and nReset pin pulled low				1	$\mu\text{A}$	
Peak calibration current <sup>(5)</sup>	VBAT = 3.3 V				450	mA	
	VBAT = 2.1 V				670		
	VBAT = 1.85 V				700		

(1) TX power level = 0 implies maximum power (see [Figure 4-1](#), [Figure 4-2](#), and [Figure 4-3](#)). TX power level = 4 implies output power backed off approximately 4 dB.

(2) The CC3220x system is a constant power-source system. The active current numbers scale based on the VBAT voltage supplied.

(3) DTIM = 1

(4) LPDS current does not include the external serial flash. The LPDS number of reported is with retention of 256KB of MCU SRAM. The CC3220x device can be configured to retain 0KB, 64KB, 128KB, 192KB, or 256KB of SRAM in LPDS. Each 64-KB block of MCU retained SRAM increases LPDS current by 4  $\mu\text{A}$ .

(5) The complete calibration can take up to 17 mJ of energy from the battery over a period of 24 ms. Calibration is performed sparingly, typically when coming out of HIBERNATE and only if temperature has changed by more than 20°C. The calibration event can be controlled by a configuration file in the serial flash..

### 4.7 TX Power and IBAT versus TX Power Level Settings

Figure 4-1, Figure 4-2, and Figure 4-3 show TX Power and IBAT versus TX power level settings for the CC3220R and CC3220S devices at modulations of 1 DSSS, 6 OFDM, and 54 OFDM, respectively. For the CC3220SF device, the IBAT current has an increase of approximately 10 mA to 15 mA depending on the transmitted rate. The TX power level will remain the same.

In Figure 4-1, the area enclosed in the circle represents a significant reduction in current during transition from TX power level 3 to level 4. In the case of lower range requirements (14-dBm output power), TI recommends using TX power level 4 to reduce the current.

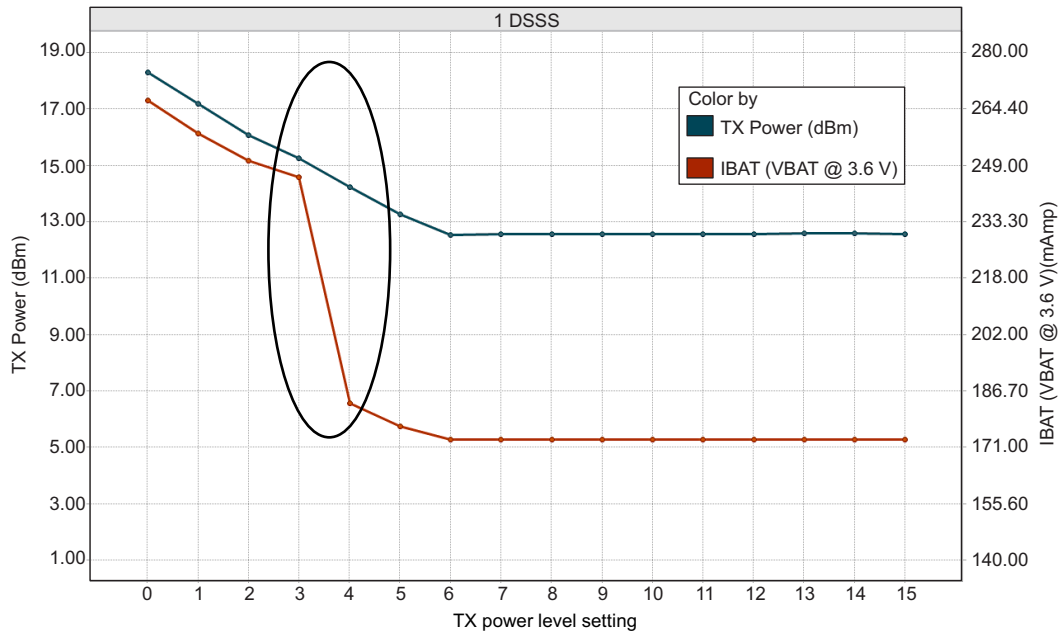

Figure 4-1. TX Power and IBAT vs TX Power Level Settings (1 DSSS)

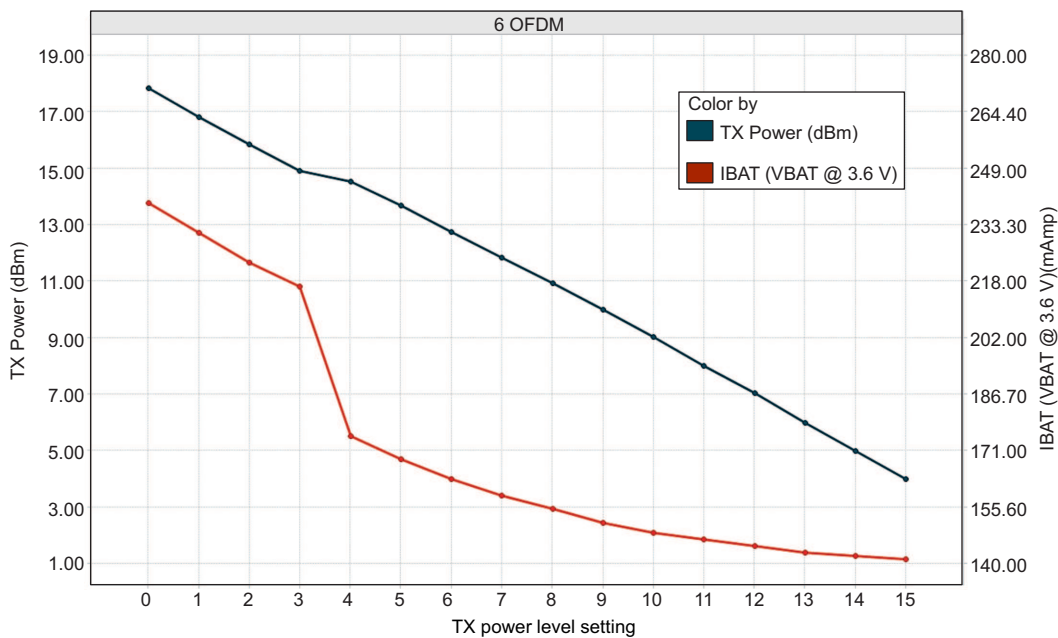

Figure 4-2. TX Power and IBAT vs TX Power Level Settings (6 OFDM)

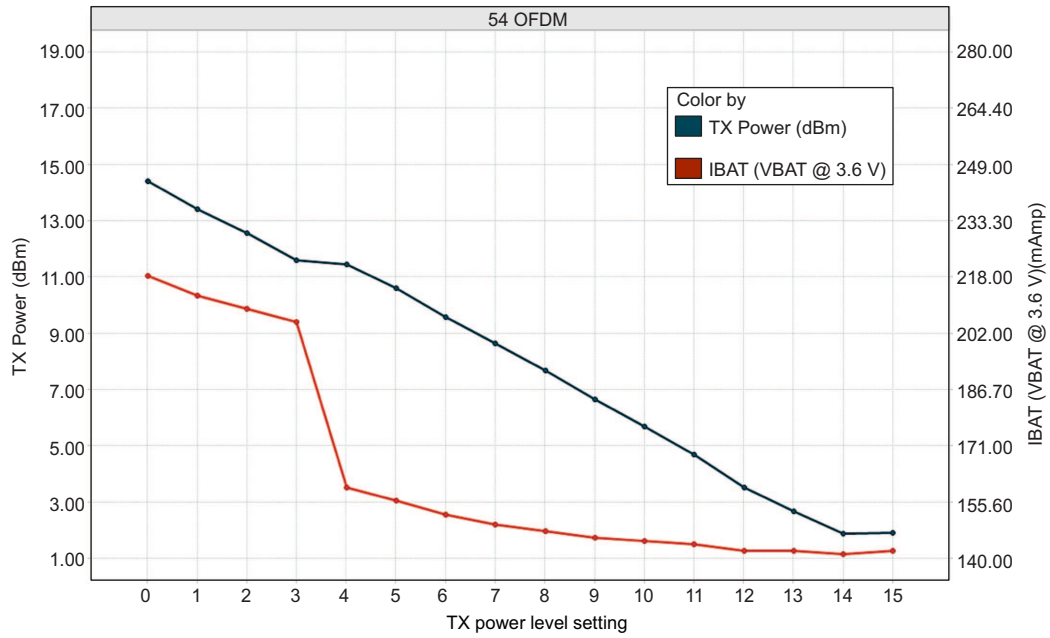

Figure 4-3. TX Power and IBAT vs TX Power Level Settings (54 OFDM)

### 4.8 Brownout and Blackout Conditions

The device enters a brownout condition when the input voltage drops below  $V_{\text{brownout}}$  (see Figure 4-4 and Figure 4-5). This condition must be considered during design of the power supply routing, especially when operating from a battery. High-current operations, such as a TX packet or any external activity (not necessarily related directly to networking) can cause a drop in the supply voltage, potentially triggering a brownout condition. The resistance includes the internal resistance of the battery, the contact resistance of the battery holder (four contacts for 2x AA batteries), and the wiring and PCB routing resistance.

**NOTE**

When the device is in HIBERNATE state, brownout is not detected. Only blackout is in effect during HIBERNATE state.

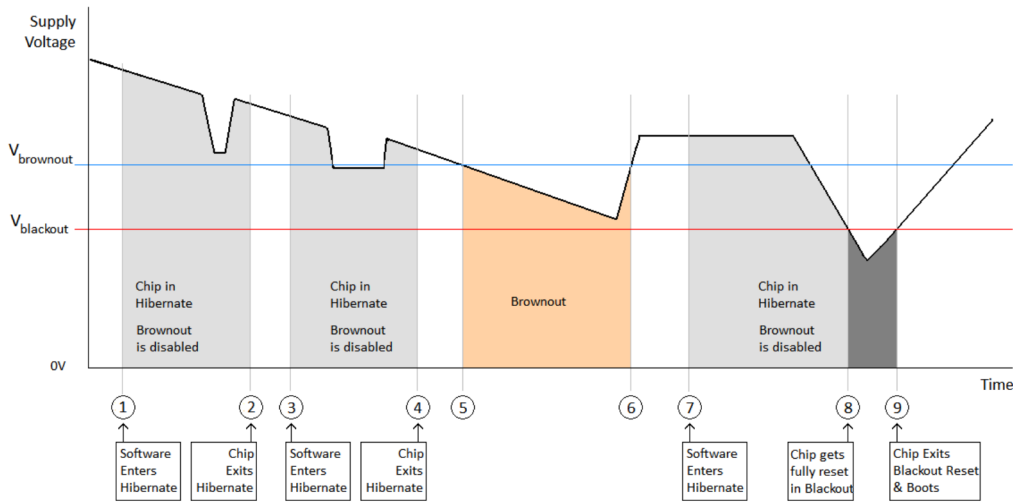

Figure 4-4. Brownout and Blackout Levels (1 of 2)

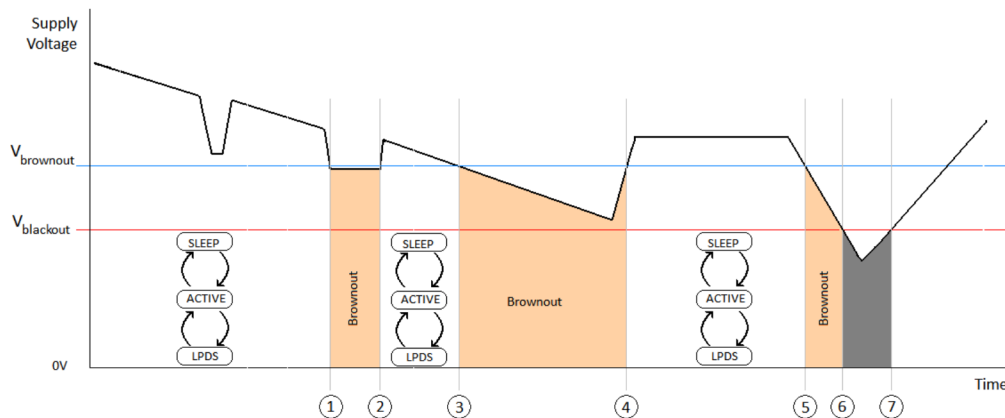

Figure 4-5. Brownout and Blackout Levels (2 of 2)

In the brownout condition, all sections of the device (including the 32-kHz RTC) shut down except for the Hibernate module, which remains on. The current in this state can reach approximately 400  $\mu$ A. The blackout condition is equivalent to a hardware reset event in which all states within the device are lost.

Table 4-1 lists the brownout and blackout voltage levels.

**Table 4-1. Brownout and Blackout Voltage Levels**

CONDITION	VOLTAGE LEVEL	UNIT
$V_{\text{brownout}}$	2.1	V
$V_{\text{blackout}}$	1.67	V

## 4.9 Electrical Characteristics (3.3 V, 25°C)

GPIO Pins Except 29, 30, 50, 52, and 53 (25°C) <sup>(1)</sup>						
PARAMETER		TEST CONDITIONS	MIN	NOM	MAX	UNIT
$C_{\text{IN}}$	Pin capacitance			4		pF
$V_{\text{IH}}$	High-level input voltage		$0.65 \times V_{\text{DD}}$		$V_{\text{DD}} + 0.5 \text{ V}$	V
$V_{\text{IL}}$	Low-level input voltage		-0.5		$0.35 \times V_{\text{DD}}$	V
$I_{\text{IH}}$	High-level input current			5		nA
$I_{\text{IL}}$	Low-level input current			5		nA
$V_{\text{OH}}$	High-level output voltage	IL = 2 mA; configured I/O drive strength = 2 mA; $2.4 \text{ V} \leq V_{\text{DD}} < 3.6 \text{ V}$			$V_{\text{DD}} \times 0.8$	V
		IL = 4 mA; configured I/O drive strength = 4 mA; $2.4 \text{ V} \leq V_{\text{DD}} < 3.6 \text{ V}$			$V_{\text{DD}} \times 0.7$	
		IL = 6 mA; configured I/O drive strength = 6 mA; $2.4 \text{ V} \leq V_{\text{DD}} < 3.6 \text{ V}$			$V_{\text{DD}} \times 0.7$	
		IL = 2 mA; configured I/O drive strength = 2 mA; $2.1 \text{ V} \leq V_{\text{DD}} < 2.4 \text{ V}$			$V_{\text{DD}} \times 0.75$	
		IL = 2 mA; configured I/O drive strength = 2 mA; $V_{\text{DD}} = 1.85 \text{ V}$			$V_{\text{DD}} \times 0.7$	
$V_{\text{OL}}$	Low-level output voltage	IL = 2 mA; configured I/O drive strength = 2 mA; $2.4 \text{ V} \leq V_{\text{DD}} < 3.6 \text{ V}$	$V_{\text{DD}} \times 0.2$			V
		IL = 4 mA; configured I/O drive strength = 4 mA; $2.4 \text{ V} \leq V_{\text{DD}} < 3.6 \text{ V}$	$V_{\text{DD}} \times 0.2$			
		IL = 6 mA; configured I/O drive strength = 6 mA; $2.4 \text{ V} \leq V_{\text{DD}} < 3.6 \text{ V}$	$V_{\text{DD}} \times 0.2$			
		IL = 2 mA; configured I/O drive strength = 2 mA; $2.1 \text{ V} \leq V_{\text{DD}} < 2.4 \text{ V}$	$V_{\text{DD}} \times 0.25$			
		IL = 2 mA; configured I/O drive strength = 2 mA; $V_{\text{DD}} = 1.85 \text{ V}$	$V_{\text{DD}} \times 0.35$			
$I_{\text{OH}}$	High-level source current,	2-mA drive		2		mA
		4-mA drive		4		
		6-mA drive		6		

(1) TI recommends using the lowest possible drive strength that is adequate for the applications. This recommendation minimizes the risk of interference to the WLAN radio and reduces any potential degradation of RF sensitivity and performance. The default drive strength setting is 6 mA.

GPIO Pins Except 29, 30, 50, 52, and 53 (25°C) <sup>(1)</sup>						
PARAMETER		TEST CONDITIONS	MIN	NOM	MAX	UNIT
I <sub>OL</sub>	Low-level sink current,	2-mA drive			2	mA
		4-mA drive			4	
		6-mA drive			6	
GPIO Pins 29, 30, 50, 52, and 53 (25°C) <sup>(1)</sup>						
PARAMETER		TEST CONDITIONS	MIN	NOM	MAX	UNIT
C <sub>IN</sub>	Pin capacitance			7		pF
V <sub>IH</sub>	High-level input voltage		0.65 × V <sub>DD</sub>		V <sub>DD</sub> + 0.5 V	V
V <sub>IL</sub>	Low-level input voltage		−0.5		0.35 × V <sub>DD</sub>	V
I <sub>IH</sub>	High-level input current			50		nA
I <sub>IL</sub>	Low-level input current			50		nA
V <sub>OH</sub>	High-level output voltage	IL = 2 mA; configured I/O drive strength = 2 mA; 2.4 V ≤ V <sub>DD</sub> < 3.6 V			V <sub>DD</sub> × 0.8	V
		IL = 4 mA; configured I/O drive strength = 4 mA; 2.4 V ≤ V <sub>DD</sub> < 3.6 V			V <sub>DD</sub> × 0.7	
		IL = 6 mA; configured I/O drive strength = 6 mA; 2.4 V ≤ V <sub>DD</sub> < 3.6 V			V <sub>DD</sub> × 0.7	
		IL = 2 mA; configured I/O drive strength = 2 mA; 2.1 V ≤ V <sub>DD</sub> < 2.4 V			V <sub>DD</sub> × 0.75	
		IL = 2 mA; configured I/O drive strength = 2 mA; V <sub>DD</sub> = 1.85 V			V <sub>DD</sub> × 0.7	
V <sub>OL</sub>	Low-level output voltage	IL = 2 mA; configured I/O drive strength = 2 mA; 2.4 V ≤ V <sub>DD</sub> < 3.6 V	V <sub>DD</sub> × 0.2			V
		IL = 4 mA; configured I/O drive strength = 4 mA; 2.4 V ≤ V <sub>DD</sub> < 3.6 V	V <sub>DD</sub> × 0.2			
		IL = 6 mA; configured I/O drive strength = 6 mA; 2.4 V ≤ V <sub>DD</sub> < 3.6 V	V <sub>DD</sub> × 0.2			
		IL = 2 mA; configured I/O drive strength = 2 mA; 2.1 V ≤ V <sub>DD</sub> < 2.4 V	V <sub>DD</sub> × 0.25			
		IL = 2 mA; configured I/O drive strength = 2 mA; V <sub>DD</sub> = 1.85 V	V <sub>DD</sub> × 0.35			
I <sub>OH</sub>	High-level source current, V <sub>OH</sub> = 2.4	2-mA drive		1.5		mA
		4-mA drive		2.5		
		6-mA drive		3.5		
I <sub>OL</sub>	Low-level sink current,	2-mA drive		1.5		mA
		4-mA drive		2.5		
		6-mA drive		3.5		
V <sub>IL</sub>	nRESET			0.6		V

- (1) TI recommends using the lowest possible drive strength that is adequate for the applications. This recommendation minimizes the risk of interference to the WLAN radio and reduces any potential degradation of RF sensitivity and performance. The default drive strength setting is 6 mA.

Pin Internal Pullup and Pulldown (25°C)					
PARAMETER	TEST CONDITIONS	MIN	NOM	MAX	UNIT
$I_{OH}$	Pullup current, $V_{OH} = 2.4$ ( $V_{DD} = 3.0$ V)	5		10	$\mu$ A
$I_{OL}$	Pulldown current, $V_{OL} = 0.4$ ( $V_{DD} = 3.0$ V)	5			$\mu$ A

#### 4.10 WLAN Receiver Characteristics

$T_A = 25^\circ\text{C}$ ,  $V_{BAT} = 2.1$  V to 3.6 V. Parameters are measured at the SoC pin on channel 6 (2437 MHz).

PARAMETER	TEST CONDITIONS (Mbps)	MIN	TYP <sup>(1)</sup>	MAX	UNIT
Sensitivity (8% PER for 11b rates, 10% PER for 11g/11n rates) (10% PER) <sup>(2)</sup>	1 DSSS		-96.0		dBm
	2 DSSS		-94.0		
	11 CCK		-88.0		
	6 OFDM		-90.5		
	9 OFDM		-90.0		
	18 OFDM		-86.5		
	36 OFDM		-80.5		
	54 OFDM		-74.5		
	MCS7 (GF) <sup>(3)</sup>		-71.5		
Maximum input level (10% PER)	802.11b		-4.0		dBm
	802.11g		-10.0		

(1) In preregulated 1.85-V mode, RX sensitivity is 0.25- to 1-dB lower.

(2) Sensitivity is 1-dB worse on channel 13 (2472 MHz).

(3) Sensitivity for mixed mode is 1-dB worse.

#### 4.11 WLAN Transmitter Characteristics

$T_A = 25^\circ\text{C}$ ,  $V_{BAT} = 2.1$  V to 3.6 V. Parameters measured at SoC pin on channel 6 (2437 MHz).<sup>(1)</sup>

PARAMETER	TEST CONDITIONS <sup>(2)</sup>	MIN	TYP	MAX	UNIT
Maximum RMS output power measured at 1 dB from IEEE spectral mask or EVM	1 DSSS		+18.0		dBm
	2 DSSS		+18.0		
	11 CCK		+18.3		
	6 OFDM		+17.3		
	9 OFDM		+17.3		
	18 OFDM		+17.0		
	36 OFDM		+16.0		
	54 OFDM		+14.5		
	MCS7 (MM)		+13.0		
Transmit center frequency accuracy		-25		25	ppm

(1) Channel-to-channel variation is up to 1 dB. The edge channels (2412 and 2472 MHz) have reduced TX power to meet FCC emission limits.

(2) In preregulated 1.85-V mode, maximum TX power is 0.25- to 0.75-dB lower for modulations higher than 18 OFDM.

## 4.12 WLAN Filter Requirements

The device requires an external band-pass filter to meet the various emission standards, including FCC. [Table 4-2](#) presents the attenuation requirements for the band-pass filter. TI recommends using the same filter used in the reference design to ease the process of certification.

**Table 4-2. WLAN Filter Requirements**

PARAMETER	FREQUENCY (MHz)	MIN	TYP	MAX	UNIT
Return loss	2412 to 2484	10			dB
Insertion loss <sup>(1)</sup>	2412 to 2484		1	1.5	dB
Attenuation	800 to 830	30	45		dB
	1600 to 1670	20	25		
	3200 to 3300	30	48		
	4000 to 4150	45	50		
	4800 to 5000	20	25		
	5600 to 5800	20	25		
	6400 to 6600	20	35		
	7200 to 7500	35	45		
	7500 to 10000	20	25		
Reference impedance	2412 to 2484		50		$\Omega$
Filter type	Bandpass				

(1) Insertion loss directly impacts output power and sensitivity. At customer discretion, insertion loss can be relaxed to meet attenuation requirements.

## 4.13 Thermal Resistance Characteristics for RGK Package

PARAMETER	AIR FLOW			
	0 lfm (C/W)	150 lfm (C/W)	250 lfm (C/W)	500 lfm (C/W)
$\theta_{ja}$	23	14.6	12.4	10.8
$\Psi_{jt}$	0.2	0.2	0.3	0.1
$\Psi_{jb}$	2.3	2.3	2.2	2.4
$\theta_{jc}$	6.3			
$\theta_{jb}$	2.4			

## 4.14 Timing and Switching Characteristics

### 4.14.1 Power Supply Sequencing

For proper operation of the CC3220x device, perform the recommended power-up sequencing as follows:

1. Tie VBAT (pins 37, 39, 44) and VIO (pins 54 and 10) together on the board.
2. Hold the RESET pin low while the supplies are ramping up. TI recommends using a simple RC circuit (100 K ||, 1  $\mu$ F, RC = 100 ms).
3. For an external RTC, ensure that the clock is stable before RESET is deasserted (high).

For timing diagrams, see [Section 4.14.3](#).

### 4.14.2 Device Reset

When a device restart is required, the user may issue a negative pulse to the nRESET pin. The user must follow one of the two alternatives to ensure the reset is properly applied:

- A negative reset pulse (on pin 32) of at least 200-mS duration
- If the above cannot be guaranteed, a pull-down resistor of 2M  $\Omega$  should be connected to pin 32 (RTC\_XTAL\_N). if implemented, a shorter pulse of at least 100  $\mu$ s can be used.

To ensure a proper reset sequence, the user has to call the sl\_stop function prior to toggling the reset. It is preferable to use software reset instead of an external trigger when a reset is required.

### 4.14.3 Reset Timing

#### 4.14.3.1 nRESET (32k XTAL)

Figure 4-6 shows the reset timing diagram for the 32k XTAL first-time power-up and reset removal.

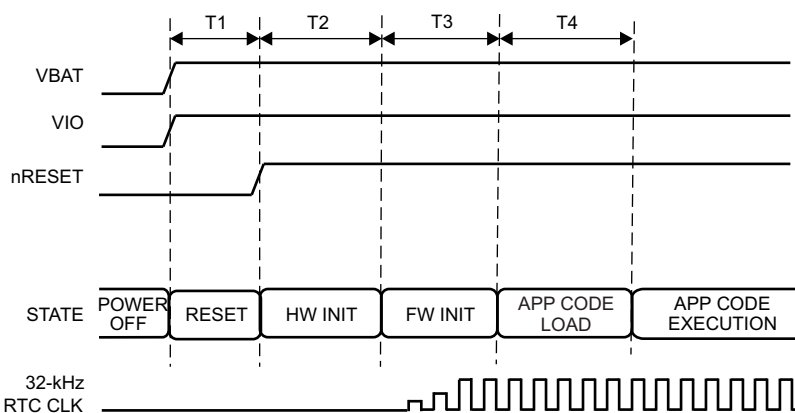

NOTE: T1 should be  $\geq 200$  ms without a pulldown resistor on the XTAL\_N pin or T1 should be  $\geq 100$   $\mu$ s if there is 2-M $\Omega$  pulldown resistor on the XTAL\_N pin.

**Figure 4-6. First-Time Power-Up and Reset Removal Timing Diagram (32k XTAL)**

Table 4-3 describes the timing requirements for the 32-kHz clock XTAL first-time power-up and reset removal.

**Table 4-3. First-Time Power-Up and Reset Removal Timing Requirements (32k XTAL)**

ITEM	NAME	DESCRIPTION	MIN	TYP	MAX	UNIT
T1	Supply settling time	Depends on application board power supply, decoupling capacitor, and so on		3		ms
T2	Hardware wake-up time			25		ms
T3	Time taken by ROM firmware to initialize hardware	Includes 32.768-kHz XOSC settling time		1.1		s
T4	App code load time for CC3220R and CC3220S	CC3220R	Image size (KB) $\times$ 0.75 ms			
		CC3220S	Image size (KB) $\times$ 1.7 ms			
	App code integrity check time for CC3220SF	CC3220SF	Image size (KB) $\times$ 0.06 ms			

### 4.14.3.2 nRESET (External 32K)

Figure 4-7 shows the reset timing diagram for the external 32K first-time power-up and reset removal.

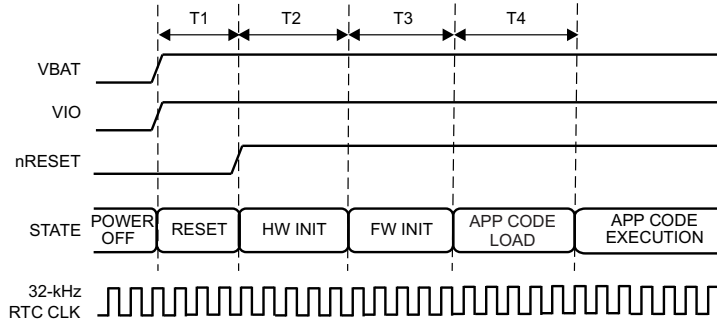

Figure 4-7. First-Time Power-Up and Reset Removal Timing Diagram (External 32K)

Table 4-4 describes the timing requirements for the external 32-kHz clock first-time power-up and reset removal.

Table 4-4. First-Time Power-Up and Reset Removal Timing Requirements (External 32K)

ITEM	NAME	DESCRIPTION	MIN	TYP	MAX	UNIT
T1	Supply settling time	Depends on application board power supply, decoupling capacitor, and so on		3		ms
T2	Hardware wake-up time			25		ms
T3	Time taken by ROM firmware to initialize hardware	CC3220R		5		ms
		CC3220S		10.3		
		CC3220SF		17.3		
T4	App code load time for CC3220R and CC3220S	CC3220R	Image size (KB) × 0.75 ms			
		CC3220S	Image size (KB) × 1.7 ms			
	App code integrity check time for CC3220SF	CC3220SF	Image size (KB) × 0.06 ms			

### 4.14.3.3 Wakeup From HIBERNATE Mode

Figure 4-8 shows the timing diagram for wakeup from HIBERNATE mode.

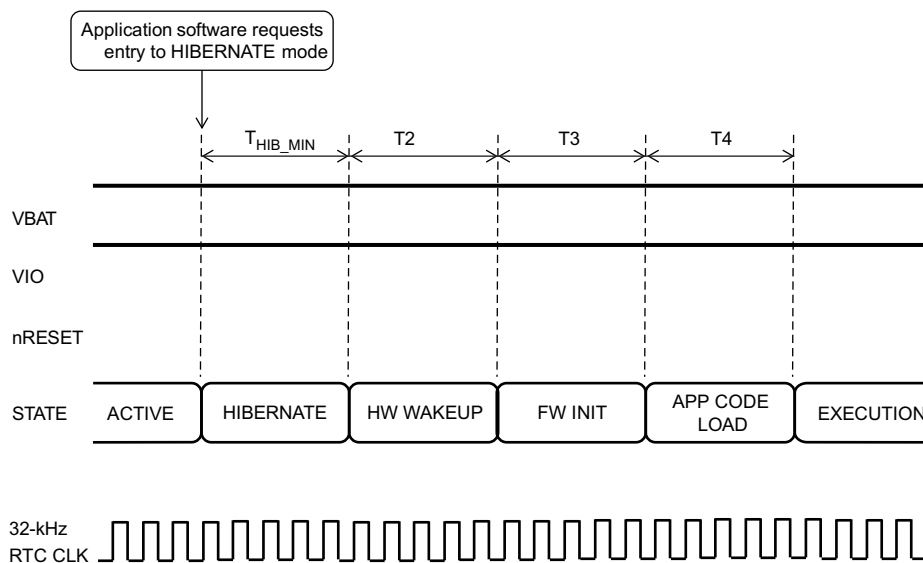

Figure 4-8. Wakeup From HIBERNATE Timing Diagram

#### NOTE

The 32.768-kHz XTAL is kept enabled by default when the chip goes into HIBERNATE mode.

describes the software hibernate timing requirements.

### 4.14.4 Clock Specifications

The CC3220x device requires two separate clocks for its operation:

- A slow clock running at 32.768 kHz is used for the RTC.
- A fast clock running at 40 MHz is used by the device for the internal processor and the WLAN subsystem.

The device features internal oscillators that enable the use of less-expensive crystals rather than dedicated TCXOs for these clocks. The RTC can also be fed externally to provide reuse of an existing clock on the system and to reduce overall cost.

#### 4.14.4.1 Slow Clock Using Internal Oscillator

The RTC crystal connected on the device supplies the free-running slow clock. The accuracy of the slow clock frequency must be 32.768 kHz  $\pm$ 150 ppm. In this mode of operation, the crystal is tied between RTC\_XTAL\_P (pin 51) and RTC\_XTAL\_N (pin 52) with a suitable load capacitance to meet the ppm requirement.

Figure 4-9 shows the crystal connections for the slow clock.

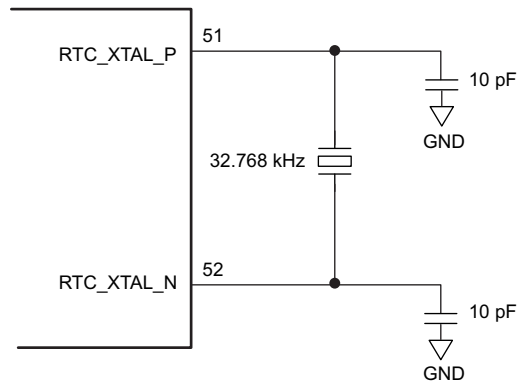

Copyright © 2017, Texas Instruments Incorporated

**Figure 4-9. RTC Crystal Connections**

Table 4-5 lists the RTC crystal requirements.

**Table 4-5. RTC Crystal Requirements**

CHARACTERISTICS	TEST CONDITIONS	MIN	TYP	MAX	UNIT
Frequency			32.768		kHz
Frequency accuracy	Initial plus temperature plus aging			±150	ppm
Crystal ESR	32.768 kHz			70	kΩ

**4.14.4.2 Slow Clock Using an External Clock**

When an RTC oscillator is present in the system, the CC3220x device can accept this clock directly as an input. The clock is fed on the RTC\_XTAL\_P line, and the RTC\_XTAL\_N line is held to VIO. The clock must be a CMOS-level clock compatible with VIO fed to the device.

Figure 4-10 shows the external RTC input connection.

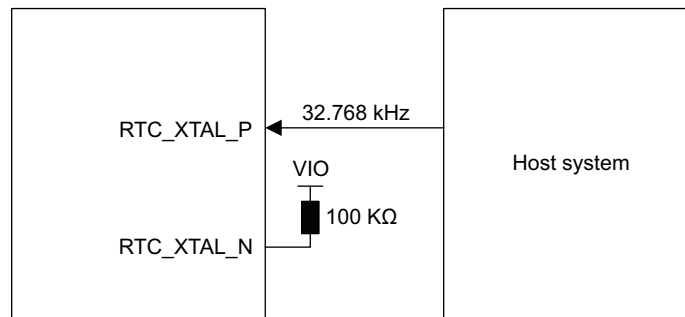

Copyright © 2017, Texas Instruments Incorporated

**Figure 4-10. External RTC Input**

Table 4-6 lists the external RTC digital clock requirements.

**Table 4-6. External RTC Digital Clock Requirements**

CHARACTERISTICS		TEST CONDITIONS	MIN	TYP	MAX	UNIT
Frequency				32768		Hz
Frequency accuracy (Initial plus temperature plus aging)				±150		ppm
$t_r, t_f$	Input transition time $t_r, t_f$ (10% to 90%)				100	ns
Frequency input duty cycle			20%	50%	80%	
$V_{ih}$	Slow clock input voltage limits	Square wave, DC coupled	0.65 × VIO		VIO	V
$V_{il}$			0	0.35 × VIO		$V_{peak}$
Input impedance			1			MΩ
					5	pF

**4.14.4.3 Fast Clock ( $F_{ref}$ ) Using an External Crystal**

The CC3220x device also incorporates an internal crystal oscillator to support a crystal-based fast clock. The XTAL is fed directly between WLAN\_XTAL\_P (pin 23) and WLAN\_XTAL\_N (pin 22) with suitable loading capacitors.

Figure 4-11 shows the crystal connections for the fast clock.

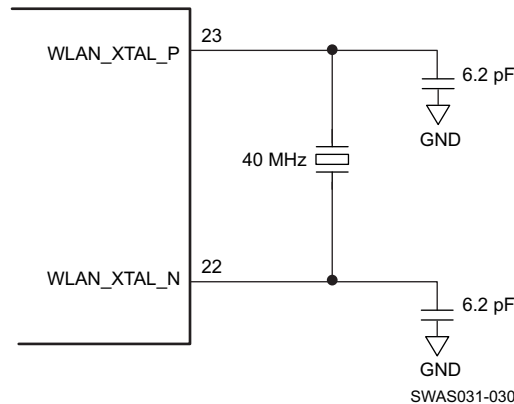

NOTE: The XTAL capacitance must be tuned to ensure that the PPM requirement is met. See [CC31xx & CC32xx Frequency Tuning](#) for information on frequency tuning.

**Figure 4-11. Fast Clock Crystal Connections**

Table 4-7 lists the WLAN fast-clock crystal requirements.

**Table 4-7. WLAN Fast-Clock Crystal Requirements**

CHARACTERISTICS	TEST CONDITIONS	MIN	TYP	MAX	UNIT
Frequency			40		MHz
Frequency accuracy	Initial plus temperature plus aging			±25	ppm
Crystal ESR	40 MHz			60	Ω

**4.14.4.4 Fast Clock ( $F_{ref}$ ) Using an External Oscillator**

The CC3220x device can accept an external TCXO/XO for the 40-MHz clock. In this mode of operation, the clock is connected to WLAN\_XTAL\_P (pin 23). WLAN\_XTAL\_N (pin 22) is connected to GND. The external TCXO/XO can be enabled by TCXO\_EN (pin 21) from the device to optimize the power consumption of the system.

If the TCXO does not have an enable input, an external LDO with an enable function can be used. Using the LDO improves noise on the TCXO power supply.

Figure 4-12 shows the connection.

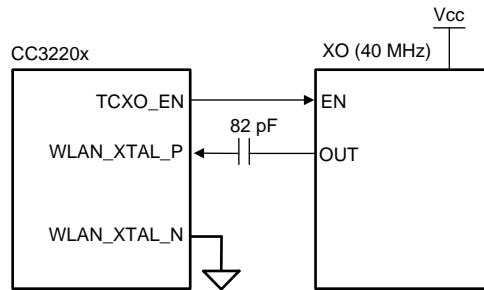

Copyright © 2017, Texas Instruments Incorporated

**Figure 4-12. External TCXO Input**

Table 4-8 lists the external  $F_{ref}$  clock requirements.

**Table 4-8. External  $F_{ref}$  Clock Requirements (–40°C to +85°C)**

CHARACTERISTICS		TEST CONDITIONS	MIN	TYP	MAX	UNIT
Frequency				40.00		MHz
Frequency accuracy (Initial plus temperature plus aging)					±25	ppm
Frequency input duty cycle			45%	50%	55%	
$V_{pp}$	Clock voltage limits	Sine or clipped sine wave, AC coupled	0.7		1.2	$V_{pp}$
Phase noise @ 40 MHz		@ 1 kHz			–125	dBc/Hz
		@ 10 kHz			–138.5	
		@ 100 kHz			–143	
Input impedance	Resistance		12			k $\Omega$
	Capacitance				7	pF

#### 4.14.5 Peripherals

This section describes the peripherals that are supported by the CC3220x device:

- SPI
- I2S
- GPIOs
- I<sup>2</sup>C
- IEEE 1149.1 JTAG
- ADC
- Camera parallel port
- UART
- SD Host
- Timers

#### 4.14.5.1 SPI

##### 4.14.5.1.1 SPI Master

The CC3220x microcontroller includes one SPI module, which can be configured as a master or slave device. The SPI includes a serial clock with programmable frequency, polarity, and phase; a programmable timing control between chip select and external clock generation; and a programmable delay before the first SPI word is transmitted. Slave mode does not include a dead cycle between two successive words.

Figure 4-13 shows the timing diagram for the SPI master.

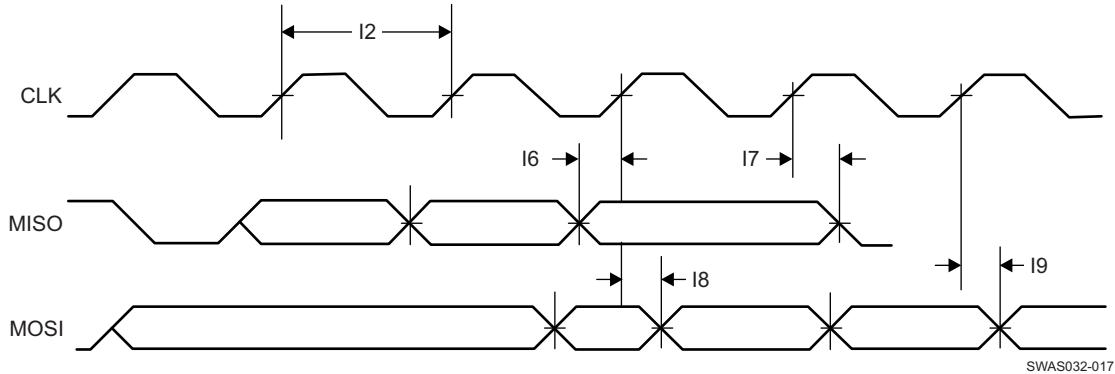

Figure 4-13. SPI Master Timing Diagram

Table 4-9 lists the timing parameters for the SPI master.

Table 4-9. SPI Master Timing Parameters

PARAMETER NUMBER			MIN	MAX	UNIT
	$F^{(1)}$	Clock frequency		20	MHz
I2	$T_{clk}^{(1)}$	Clock period	50		ns
	$D^{(1)}$	Duty cycle	45%	55%	
I6	$t_{IS}^{(1)}$	RX data setup time	1		ns
I7	$t_{IH}^{(1)}$	RX data hold time	2		ns
I8	$t_{OD}^{(1)}$	TX data output delay		8.5	ns
I9	$t_{OH}^{(1)}$	TX data hold time		8	ns

(1) Timing parameter assumes a maximum load of 20 pF.

4.14.5.1.2 SPI Slave

Figure 4-14 shows the timing diagram for the SPI slave.

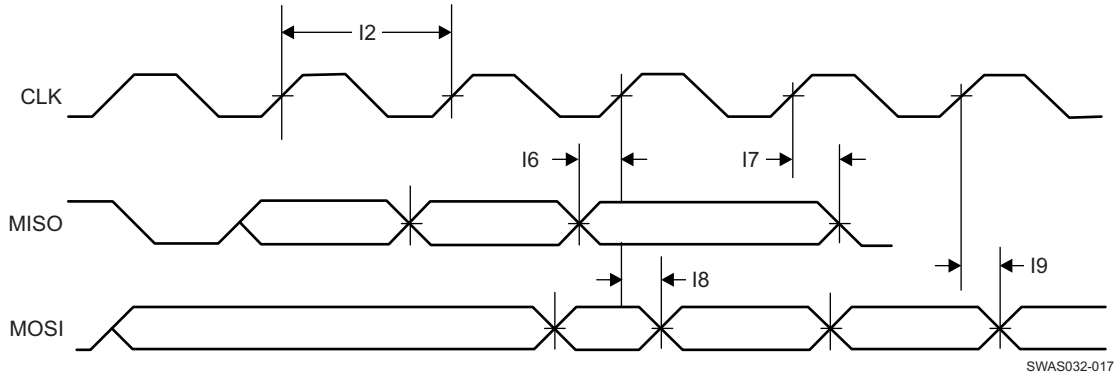

Figure 4-14. SPI Slave Timing Diagram

Table 4-10 lists the timing parameters for the SPI slave.

Table 4-10. SPI Slave Timing Parameters

PARAMETER NUMBER			MIN	MAX	UNIT
	F <sup>(1)</sup>	Clock frequency @ VBAT = 3.3 V		20	MHz
		Clock frequency @ VBAT ≤ 2.1 V		12	
I2	T <sub>clk</sub> <sup>(1)</sup>	Clock period	50		ns
	D <sup>(1)</sup>	Duty cycle	45%	55%	
I6	t <sub>IS</sub> <sup>(1)</sup>	RX data setup time	4		ns
I7	t <sub>IH</sub> <sup>(1)</sup>	RX data hold time	4		ns
I8	t <sub>OD</sub> <sup>(1)</sup>	TX data output delay		20	ns
I9	t <sub>OH</sub> <sup>(1)</sup>	TX data hold time		24	ns

(1) Timing parameter assumes a maximum load of 20 pF at 3.3 V.

#### 4.14.5.2 I2S

The McASP interface functions as a general-purpose audio serial port optimized for multichannel audio applications and supports transfer of two stereo channels over two data pins. The McASP consists of transmit and receive sections that operate synchronously and have programmable clock and frame-sync polarity. A fractional divider is available for bit-clock generation.

##### 4.14.5.2.1 I2S Transmit Mode

Figure 4-15 shows the timing diagram for the I2S transmit mode.

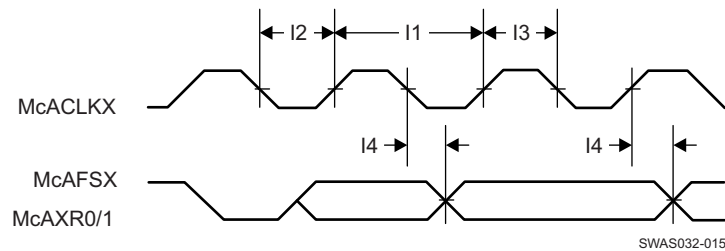

Figure 4-15. I2S Transmit Mode Timing Diagram

Table 4-11 lists the timing parameters for the I2S transmit mode.

Table 4-11. I2S Transmit Mode Timing Parameters

PARAMETER NUMBER			MIN	MAX	UNIT
I1	$f_{clk}^{(1)}$	Clock frequency		9.216	MHz
I2	$t_{LP}^{(1)}$	Clock low period		1/2 fclk	ns
I3	$t_{HT}^{(1)}$	Clock high period		1/2 fclk	ns
I4	$t_{OH}^{(1)}$	TX data hold time		22	ns

(1) Timing parameter assumes a maximum load of 20 pF.

##### 4.14.5.2.2 I2S Receive Mode

Figure 4-16 shows the timing diagram for the I2S receive mode.

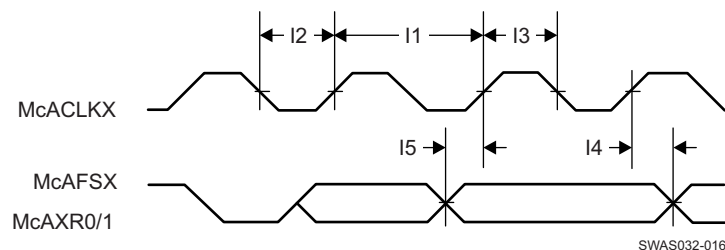

Figure 4-16. I2S Receive Mode Timing Diagram

Table 4-12 lists the timing parameters for the I2S receive mode.

**Table 4-12. I2S Receive Mode Timing Parameters**

PARAMETER NUMBER			MIN	MAX	UNIT
I1	$f_{\text{clk}}^{(1)}$	Clock frequency		9.216	MHz
I2	$t_{\text{LP}}^{(1)}$	Clock low period		$1/2 f_{\text{clk}}$	ns
I3	$t_{\text{HT}}^{(1)}$	Clock high period		$1/2 f_{\text{clk}}$	ns
I4	$t_{\text{OH}}^{(1)}$	RX data hold time		0	ns
I5	$t_{\text{OS}}^{(1)}$	RX data setup time		15	ns

(1) Timing parameter assumes a maximum load of 20 pF.

#### 4.14.5.3 GPIOs

All digital pins of the device can be used as general-purpose input/output (GPIO) pins. The GPIO module consists of four GPIO blocks, each of which provides eight GPIOs. The GPIO module supports 24 programmable GPIO pins, depending on the peripheral used. Each GPIO has configurable pullup and pulldown strength (weak 10  $\mu\text{A}$ ), configurable drive strength (2, 4, and 6 mA), and open-drain enable.

Figure 4-17 shows the GPIO timing diagram.

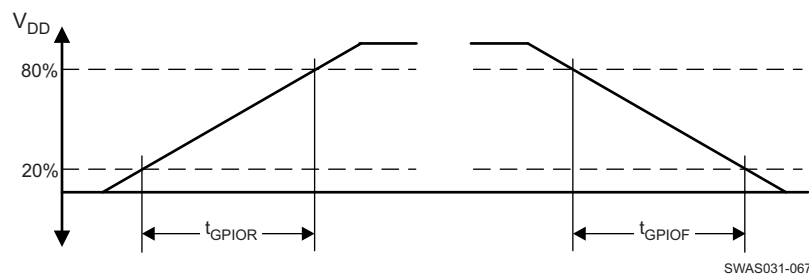

**Figure 4-17. GPIO Timing Diagram**

##### 4.14.5.3.1 GPIO Output Transition Time Parameters ( $V_{\text{supply}} = 3.3 \text{ V}$ )

Table 4-13 lists the GPIO output transition times for  $V_{\text{supply}} = 3.3 \text{ V}$ .

**Table 4-13. GPIO Output Transition Times ( $V_{\text{supply}} = 3.3 \text{ V}$ )<sup>(1)(2)</sup>**

DRIVE STRENGTH (mA)	DRIVE STRENGTH CONTROL BITS	$T_r$			$T_f$			UNIT
		MIN	NOM	MAX	MIN	NOM	MAX	
2	2MA_EN=1	8.0	9.3	10.7	8.2	9.5	11.0	ns
	4MA_EN=0							
4	2MA_EN=0	6.6	7.1	7.6	4.7	5.2	5.8	ns
	4MA_EN=1							
6	2MA_EN=1	3.2	3.5	3.7	2.3	2.6	2.9	ns
	4MA_EN=1							

(1)  $V_{\text{supply}} = 3.3 \text{ V}$ ,  $T = 25^\circ\text{C}$ , total pin load = 30 pF

(2) The transition data applies to the pins except the multiplexed analog-digital pins 29, 30, 45, 50, 52, and 53.

**4.14.5.3.2 GPIO Output Transition Time Parameters ( $V_{supply} = 1.85 V$ )**

Table 4-14 lists the GPIO output transition times for  $V_{supply} = 1.8 V$ .

**Table 4-14. GPIO Output Transition Times ( $V_{supply} = 1.85 V$ )<sup>(1)(2)</sup>**

DRIVE STRENGTH (mA)	DRIVE STRENGTH CONTROL BITS	$T_r$			$T_f$			UNIT
		MIN	NOM	MAX	MIN	NOM	MAX	
2	2MA_EN=1	11.7	13.9	16.3	11.5	13.9	16.7	ns
	4MA_EN=0							
4	2MA_EN=0	13.7	15.6	18.0	9.9	11.6	13.6	ns
	4MA_EN=1							
6	2MA_EN=1	5.5	6.4	7.4	3.8	4.7	5.8	ns
	4MA_EN=1							

(1)  $V_{supply} = 1.8 V$ ,  $T = 25^{\circ}C$ , total pin load = 30 pF

(2) The transition data applies to the pins other than the multiplexed analog-digital pins 29, 30, 45, 50, 52, and 53.

**4.14.5.3.3 GPIO Input Transition Time Parameters**

Table 4-15 lists the input transition time parameters.

**Table 4-15. GPIO Input Transition Time Parameters**

		MIN	MAX	UNIT
$t_r$	Input transition time ( $t_r$ , $t_f$ ), 10% to 90%	1	3	ns
$t_f$		1	3	ns

**4.14.5.4 I<sup>2</sup>C**

The CC3220x microcontroller includes one I2C module operating with standard (100 kbps) or fast (400 kbps) transmission speeds.

Figure 4-18 shows the I<sup>2</sup>C timing diagram.

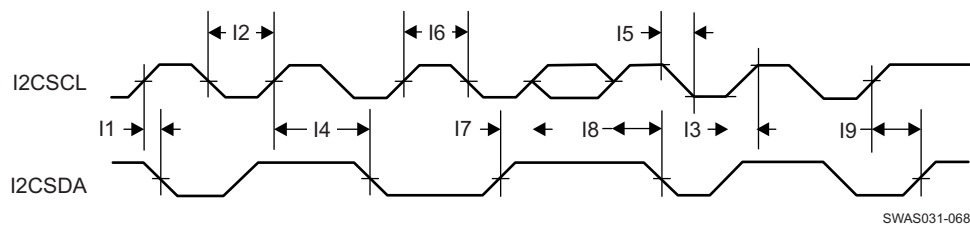

**Figure 4-18. I<sup>2</sup>C Timing Diagram**

Table 4-16 lists the I<sup>2</sup>C timing parameters.

**Table 4-16. I<sup>2</sup>C Timing Parameters<sup>(1)</sup>**

PARAMETER NUMBER			MIN	MAX	UNIT
I2	t <sub>LP</sub>	Clock low period	See <sup>(2)</sup>		System clock
I3	t <sub>SRT</sub>	SCL/SDA rise time		See <sup>(3)</sup>	ns
I4	t <sub>DH</sub>	Data hold time	NA		
I5	t <sub>SFT</sub>	SCL/SDA fall time	3		ns
I6	t <sub>HT</sub>	Clock high time	See <sup>(2)</sup>		System clock
I7	t <sub>DS</sub>	Data setup time	t <sub>LP</sub> /2		System clock
I8	t <sub>SCSR</sub>	Start condition setup time	36		System clock
I9	t <sub>SCS</sub>	Stop condition setup time	24		System clock

(1) All timing is with 6-mA drive and 20-pF load.

(2) This value depends on the value programmed in the clock period register of I<sup>2</sup>C. Maximum output frequency is the result of the minimal value programmed in this register.

(3) Because I<sup>2</sup>C is an open-drain interface, the controller can drive logic 0 only. Logic 1 is the result of external pullup. Rise time depends on the value of the external signal capacitance and external pullup register.

#### 4.14.5.5 IEEE 1149.1 JTAG

The Joint Test Action Group (JTAG) port is an IEEE standard that defines a test access port (TAP) and boundary scan architecture for digital integrated circuits and provides a standardized serial interface to control the associated test logic. For detailed information on the operation of the JTAG port and TAP controller, see the IEEE Standard 1149.1, *Test Access Port and Boundary-Scan Architecture*.

Figure 4-19 shows the JTAG timing diagram.

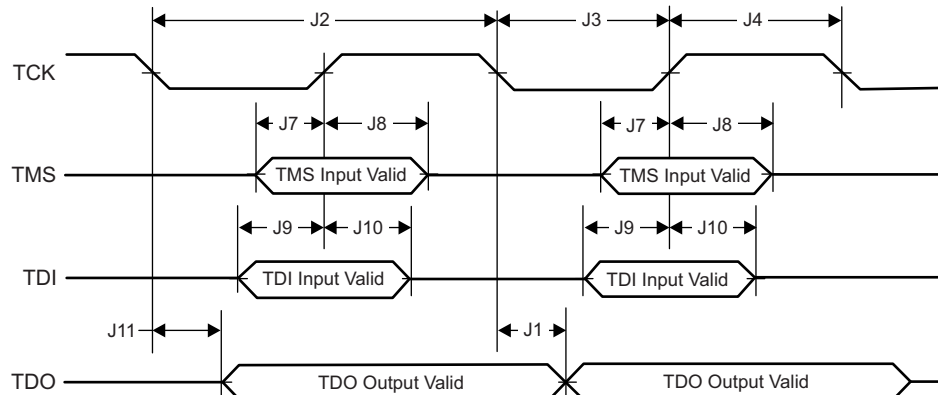

SWAS031-069

**Figure 4-19. JTAG Timing Diagram**

Table 4-17 lists the JTAG timing parameters.

**Table 4-17. JTAG Timing Parameters**

PARAMETER NUMBER			MIN	MAX	UNIT
J1	f <sub>TCK</sub>	Clock frequency		15	MHz
J2	t <sub>TCK</sub>	Clock period		1 / f <sub>TCK</sub>	ns
J3	t <sub>CL</sub>	Clock low period		t <sub>TCK</sub> / 2	ns
J4	t <sub>CH</sub>	Clock high period		t <sub>TCK</sub> / 2	ns
J7	t <sub>TMS_SU</sub>	TMS setup time	1		ns
J8	t <sub>TMS_HO</sub>	TMS hold time	16		ns

**Table 4-17. JTAG Timing Parameters (continued)**

PARAMETER NUMBER			MIN	MAX	UNIT
J9	t <sub>TDI_SU</sub>	TDI setup time	1		ns
J10	t <sub>TDI_HO</sub>	TDI hold time	16		ns
J11	t <sub>TDO_HO</sub>	TDO hold time		15	ns

#### 4.14.5.6 ADC

Table 4-18 lists the ADC electrical specifications. See [CC32xx ADC Appnote](#) for further information on using the ADC and for application-specific examples.

**Table 4-18. ADC Electrical Specifications**

PARAMETER	DESCRIPTION	TEST CONDITIONS and ASSUMPTIONS	MIN	TYP	MAX	UNIT
Nbits	Number of bits			12		Bits
INL	Integral nonlinearity	Worst-case deviation from histogram method over full scale (not including first and last three LSB levels)	-2.5		2.5	LSB
DNL	Differential nonlinearity	Worst-case deviation of any step from ideal	-1		4	LSB
Input range			0		1.4	V
Driving source impedance					100	Ω
FCLK	Clock rate	Successive approximation input clock rate		10		MHz
Input capacitance				12		pF
Input impedance		ADC Pin 57		2.15		kΩ
		ADC Pin 58		0.7		
		ADC Pin 59		2.12		
		ADC Pin 60		1.17		
Number of channels			4			
F <sub>sample</sub>	Sampling rate of each pin			62.5		KSPS
F <sub>input_max</sub>	Maximum input signal frequency				31	kHz
SINAD	Signal-to-noise and distortion	Input frequency DC to 300 Hz and 1.4 V <sub>pp</sub> sine wave input	55	60		dB
I <sub>active</sub>	Active supply current	Average for analog-to-digital during conversion without reference current		1.5		mA
I <sub>PD</sub>	Power-down supply current for core supply	Total for analog-to-digital when not active (this must be the SoC level test)		1		μA
Absolute offset error		FCLK = 10 MHz		±2		mV
Gain error				±2%		
V <sub>ref</sub>	ADC reference voltage			1.467		V

Figure 4-20 shows the ADC clock timing diagram.

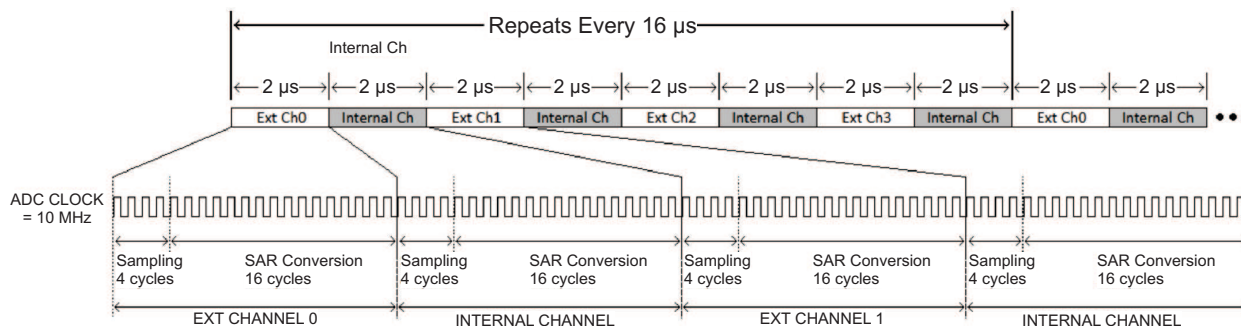

Figure 4-20. ADC Clock Timing Diagram

#### 4.14.5.7 Camera Parallel Port

The fast camera parallel port interfaces with a variety of external image sensors, stores the image data in a FIFO, and generates DMA requests. The camera parallel port supports 8 bits.

Figure 4-21 shows the timing diagram for the camera parallel port.

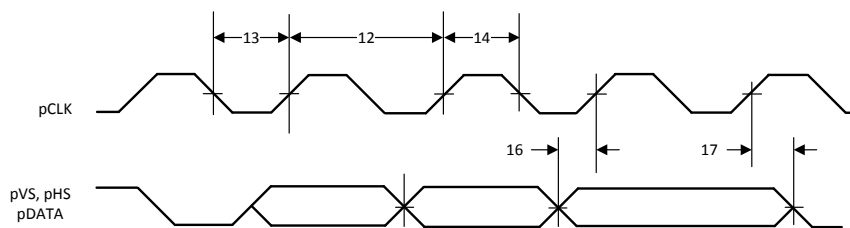

Figure 4-21. Camera Parallel Port Timing Diagram

Table 4-19 lists the timing parameters for the camera parallel port.

Table 4-19. Camera Parallel Port Timing Parameters

PARAMETER NUMBER			MIN	MAX	UNIT
	pCLK	Clock frequency		2	MHz
12	$T_{clk}$	Clock period		$1/pCLK$	ns
13	$t_{LP}$	Clock low period		$T_{clk}/2$	ns
14	$t_{HT}$	Clock high period		$T_{clk}/2$	ns
16	$t_{IS}$	RX data setup time		2	ns
17	$t_{IH}$	RX data hold time		2	ns
	D	Duty cycle	45%	55%	

#### 4.14.5.8 UART

The CC3220x device includes two UARTs with the following features:

- Programmable baud-rate generator allowing speeds up to 3 Mbps
- Separate 16-bit x 8-bit TX and RX FIFOs to reduce CPU interrupt service loading
- Programmable FIFO length, including a 1-byte-deep operation providing conventional double-buffered interface
- FIFO trigger levels of 1/8, 1/4, 1/2, 3/4, and 7/8
- Standard asynchronous communication bits for start, stop, and parity
- Generation and detection of line-breaks

- Fully programmable serial interface characteristics:
  - 5, 6, 7, or 8 data bits
  - Generation and detection of even, odd, stick, or no-parity bits
  - Generation of 1 or 2 stop-bits
- RTS and CTS hardware flow support
- Standard FIFO-level and End-of-Transmission interrupts
- Efficient transfers using  $\mu$ DMA:
  - Separate channels for transmit and receive
  - Receive single request asserted when data is in the FIFO; burst request asserted at programmed FIFO level
  - Transmit single request asserted when there is space in the FIFO; burst request asserted at programmed FIFO level
- System clock is used to generate the baud clock.

#### 4.14.5.9 SD Host

CC3220x provides an interface between a local host (LH), such as an MCU and an SD memory card, and handles SD transactions with minimal LH intervention.

The SD host does the following:

- Provides SD card access in 1-bit mode
- Deals with SD protocol at the transmission level
- Handles data packing
- Adds cyclic redundancy checks (CRC)
- Start and end bit
- Checks for syntactical correctness

The application interface sends every SD command and either polls for the status of the adapter or waits for an interrupt request. The result is then sent back to the application interface in case of exceptions or to warn of end-of-operation. The controller can be configured to generate DMA requests and work with minimum CPU intervention. Given the nature of integration of this peripheral on the CC3220x platform, TI recommends that developers use peripheral library APIs to control and operate the block. This section emphasizes understanding the SD host APIs provided in the peripheral library of the CC3220x Software Development Kit (SDK).

The SD Host features are as follows:

- Full compliance with SD command and response sets, as defined in the SD memory card
  - Specifications, v2.0
  - Includes high-capacity (size >2 GB) cards HC SD
- Flexible architecture, allowing support for new command structure.
- 1-bit transfer mode specifications for SD cards
- Built-in 1024-byte buffer for read or write
  - 512-byte buffer for both transmit and receive
  - Each buffer is 32-bits wide by 128-words deep
- 32-bit-wide access bus to maximize bus throughput
- Single interrupt line for multiple interrupt source events
- Two slave DMA channels (1 for TX, 1 for RX)
- Programmable clock generation
- Integrates an internal transceiver that allows a direct connection to the SD card without external transceiver
- Supports configurable busy and response timeout

- Support for a wide range of card clock frequency with odd and even clock ratio
- Maximum frequency supported is 24 MHz

#### 4.14.5.10 Timers

Programmable timers can be used to count or time external events that drive the timer input pins. The CC3220x general-purpose timer module (GPTM) contains 16- or 32-bit GPTM blocks. Each 16- or 32-bit GPTM block provides two 16-bit timers or counters (referred to as Timer A and Timer B) that can be configured to operate independently as timers or event counters, or they can be concatenated to operate as one 32-bit timer. Timers can also be used to trigger  $\mu$ DMA transfers.

The GPTM contains four 16- or 32-bit GPTM blocks with the following functional options:

- Operating modes:
  - 16- or 32-bit programmable one-shot timer
  - 16- or 32-bit programmable periodic timer
  - 16-bit general-purpose timer with an 8-bit prescaler
  - 16-bit input-edge count- or time-capture modes with an 8-bit prescaler
  - 16-bit PWM mode with an 8-bit prescaler and software-programmable output inversion of the PWM signal
- Counts up or counts down
- Sixteen 16- or 32-bit capture compare PWM pins (CCP)
- User-enabled stalling when the microcontroller asserts CPU Halt flag during debug
- Ability to determine the elapsed time between the assertion of the timer interrupt and entry into the interrupt service routine
- Efficient transfers using micro direct memory access controller ( $\mu$ DMA):
  - Dedicated channel for each timer
  - Burst request generated on timer interrupt
- Runs from system clock (80 MHz)

## 5 Detailed Description

### 5.1 Overview

The CC3220x wireless MCU family has a rich set of peripherals for diverse application requirements. This section briefly highlights the internal details of the CC3220x devices and offers suggestions for application configurations.

### 5.2 Functional Block Diagram

Figure 5-1 shows the functional block diagram of the CC3220x SimpleLink Wi-Fi solution.

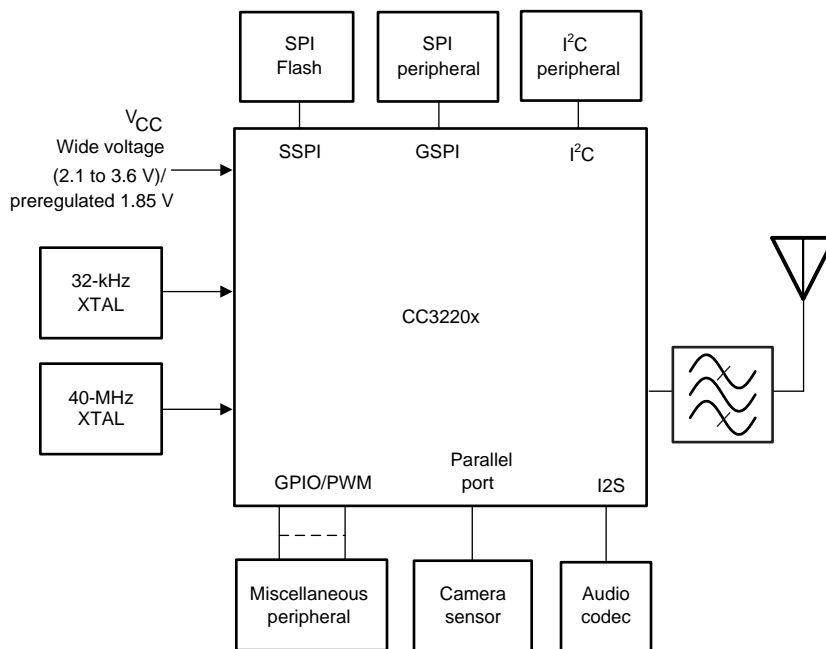

Copyright © 2017, Texas Instruments Incorporated

**Figure 5-1. Functional Block Diagram**

### 5.3 ARM® Cortex®-M4 Processor Core Subsystem

The high-performance Cortex-M4 processor provides a low-cost platform that meets the needs of minimal memory implementation, reduced pin count, and low power consumption, while delivering outstanding computational performance and exceptional system response to interrupts.

- The Cortex-M4 core has low-latency interrupt processing with the following features:
  - A 32-bit ARM® Thumb® instruction set optimized for embedded applications
  - Handler and thread modes
  - Low-latency interrupt handling by automatic processor state saving and restoration during entry and exit
  - Support for ARMv6 unaligned accesses
- Nested vectored interrupt controller (NVIC) closely integrated with the processor core to achieve low-latency interrupt processing. The NVIC includes the following features:
  - Bits of priority configurable from 3 to 8
  - Dynamic reprioritization of interrupts
  - Priority grouping that enables selection of preempting interrupt levels and nonpreempting interrupt levels
  - Support for tail-chaining and late arrival of interrupts, which enables back-to-back interrupt processing without the overhead of state saving and restoration between interrupts
  - Processor state automatically saved on interrupt entry and restored on interrupt exit with no instruction overhead
  - Wake-up interrupt controller (WIC) providing ultra-low-power sleep mode support
- Bus interfaces:
  - Advanced high-performance bus (AHB-Lite) interfaces: system bus interfaces
  - Bit-band support for memory and select peripheral that includes atomic bit-band write and read operations
- Low-cost debug solution featuring:
  - Debug access to all memory and registers in the system, including access to memory-mapped devices, access to internal core registers when the core is halted, and access to debug control registers even while SYSRESETn is asserted
  - Serial wire debug port (SW-DP) or serial wire JTAG debug port (SWJ-DP) debug access
  - Flash patch and breakpoint (FPB) unit to implement breakpoints and code patches

### 5.4 Wi-Fi Network Processor Subsystem

The Wi-Fi network processor subsystem includes a dedicated ARM MCU to completely offload the host MCU along with an 802.11 b/g/n radio, baseband, and MAC with a powerful crypto engine for a fast, secure WLAN and Internet connections with 256-bit encryption. The CC3220x devices support station, AP, and Wi-Fi Direct modes. The device also supports WPA2 personal and enterprise security and WPS 2.0. The Wi-Fi network processor includes an embedded IPv6, IPv4 TCP/IP stack.

### 5.4.1 WLAN

The WLAN features are as follows:

- 802.11b/g/n integrated radio, modem, and MAC supporting WLAN communication as a BSS station, AP, Wi-Fi Direct client and group owner with CCK and OFDM rates in the 2.4-GHz ISM band, channels 1 to 13.

---

#### NOTE

802.11n is supported only in Wi-Fi station, Wi-Fi direct, and P2P client modes.

---

- Autocalibrated radio with a single-ended 50-Ω interface enables easy connection to the antenna without requiring expertise in radio circuit design.
- Advanced connection manager with multiple user-configurable profiles stored in serial-flash allows automatic fast connection to an access point without user or host intervention.
- Supports all common Wi-Fi security modes for personal and enterprise networks with on-chip security accelerators, including: WEP, WPA/WPA2 PSK, WPA2 Enterprise (802.1x).
- Smart provisioning options deeply integrated within the device providing a comprehensive end-to-end solution. With elaborate events notification to the host, enabling the application to control the provisioning decision flow. The wide variety of Wi-Fi provisioning methods include:
  - Access Point using HTTPS
  - SmartConfig Technology: a 1-step, 1-time process to connect a CC3220-enabled device to the home wireless network, removing dependency on the I/O capabilities of the host MCU; thus, it is usable by deeply embedded applications
- 802.11 transceiver mode allows transmitting and receiving of proprietary data through a socket without adding MAC or PHY headers. The 802.11 transceiver mode provides the option to select the working channel, rate, and transmitted power. The receiver mode works with the filtering options.

### 5.4.2 Network Stack

The Network Stack features are as follows:

- Integrated IPv4, IPv6 TCP/IP stack with BSD (BSD adjacent) socket APIs for simple Internet connectivity with any MCU, microprocessor, or ASIC

---

#### NOTE

Not all APIs are 100% BSD compliant. Not all BSD APIs are supported.

---

- Support of 16 simultaneous TCP, UDP, or RAW sockets
- Support of 6 simultaneous SSL/TLS sockets
- Built-in network protocols:
  - Static IP, LLA, DHCPv4, DHCPv6 with DAD and stateless autoconfiguration
  - ARP, ICMPv4, IGMP, ICMPv6, MLD, ND
  - DNS client for easy connection to the local network and the Internet

- Built-in network application and utilities:
  - HTTP/HTTPS
    - Web page content stored on serial flash
    - RESTful APIs for setting and configuring application content
    - Dynamic user callbacks
  - Service discovery: Multicast DNS service discovery lets a client advertise its service without a centralized server. After connecting to the access point, the CC3220x device provides critical information, such as device name, IP, vendor, and port number.
  - DHCP server
  - Ping

Table 5-1 describes the NWP features.

**Table 5-1. NWP Features**

Feature	Description
Wi-Fi standards	802.11b/g/n station 802.11b/g AP supporting up to four stations Wi-Fi Direct client and group owner
Wi-Fi channels	1 to 13
Wi-Fi security	WEP, WPA/WPA2 PSK, WPA2 enterprise (802.1x)
Wi-Fi provisioning	SmartConfig technology, Wi-Fi protected setup (WPS2), AP mode with internal HTTP web server
IP protocols	IPv4/IPv6
IP addressing	Static IP, LLA, DHCPv4, DHCPv6 with DAD
Cross layer	ARP, ICMPv4, IGMP, ICMPv6, MLD, NDP
Transport	UDP, TCP SSLv3.0/TLSv1.0/TLSv1.1/TLSv1.2 RAW
Network applications and utilities	Ping HTTP/HTTPS web server mDNS DNS-SD DHCP server
Host interface	UART/SPI
Security	Device identity Trusted root-certificate catalog TI root-of-trust public key The CC3220S and CC3220SF variants also support: <ul style="list-style-type: none"> <li>• Secure key storage</li> <li>• File system security</li> <li>• Software tamper detection</li> <li>• Cloning protection</li> <li>• Secure boot</li> <li>• Validate the integrity and authenticity of the run-time binary during boot</li> <li>• Initial secure programming</li> <li>• Debug security</li> <li>• JTAG and debug</li> </ul>
Power management	Enhanced power policy management uses 802.11 power save and deep-sleep power modes
Other	Transceiver Programmable RX filters with event-trigger mechanism

## 5.5 Security

The SimpleLink Wi-Fi CC3220x Internet-on-a-Chip device enhances the security capabilities available for development of IoT devices, while completely offloading these activities from the MCU to the networking subsystem. The security capabilities include the following key features:

### Wi-Fi and Internet Security:

- Personal and enterprise Wi-Fi security
  - Personal standards
    - AES (WPA2-PSK)
    - TKIP (WPA-PSK)
    - WEP
  - Enterprise standards
    - EAP Fast
    - EAP PEAPv0/1
    - EAP PEAPv0 TLS
    - EAP PEAPv1 TLS EAP LS
    - EAP TLS
    - EAP TTLS TLS
    - EAP TTLS MSCHAPv2

- Secure sockets
  - Protocol versions: SSL v3, TLS 1.0, TLS 1.1, TLS 1.2
  - Powerful crypto engine for fast, secure Wi-Fi and internet connections with 256-bit AES encryption for TLS and SSL connections
  - Ciphers suites
    - SL\_SEC\_MASK\_SSL\_RSA\_WITH\_RC4\_128\_SHA
    - SL\_SEC\_MASK\_SSL\_RSA\_WITH\_RC4\_128\_MD5
    - SL\_SEC\_MASK\_TLS\_RSA\_WITH\_AES\_256\_CBC\_SHA
    - SL\_SEC\_MASK\_TLS\_DHE\_RSA\_WITH\_AES\_256\_CBC\_SHA
    - SL\_SEC\_MASK\_TLS\_ECDHE\_RSA\_WITH\_AES\_256\_CBC\_SHA
    - SL\_SEC\_MASK\_TLS\_ECDHE\_RSA\_WITH\_RC4\_128\_SHA
    - SL\_SEC\_MASK\_TLS\_RSA\_WITH\_AES\_128\_CBC\_SHA256
    - SL\_SEC\_MASK\_TLS\_RSA\_WITH\_AES\_256\_CBC\_SHA256
    - SL\_SEC\_MASK\_TLS\_ECDHE\_RSA\_WITH\_AES\_128\_CBC\_SHA256
    - SL\_SEC\_MASK\_TLS\_ECDHE\_ECDSA\_WITH\_AES\_128\_CBC\_SHA256
    - SL\_SEC\_MASK\_TLS\_ECDHE\_ECDSA\_WITH\_AES\_256\_CBC\_SHA
    - SL\_SEC\_MASK\_TLS\_RSA\_WITH\_AES\_128\_GCM\_SHA256
    - SL\_SEC\_MASK\_TLS\_RSA\_WITH\_AES\_256\_GCM\_SHA384
    - SL\_SEC\_MASK\_TLS\_DHE\_RSA\_WITH\_AES\_128\_GCM\_SHA256
    - SL\_SEC\_MASK\_TLS\_DHE\_RSA\_WITH\_AES\_256\_GCM\_SHA384
    - SL\_SEC\_MASK\_TLS\_ECDHE\_RSA\_WITH\_AES\_128\_GCM\_SHA256
    - SL\_SEC\_MASK\_TLS\_ECDHE\_RSA\_WITH\_AES\_256\_GCM\_SHA384
    - SL\_SEC\_MASK\_TLS\_ECDHE\_ECDSA\_WITH\_AES\_128\_GCM\_SHA256
    - SL\_SEC\_MASK\_TLS\_ECDHE\_ECDSA\_WITH\_AES\_256\_GCM\_SHA384
    - SL\_SEC\_MASK\_TLS\_ECDHE\_ECDSA\_WITH\_CHACHA20\_POLY1305\_SHA256
    - SL\_SEC\_MASK\_TLS\_ECDHE\_RSA\_WITH\_CHACHA20\_POLY1305\_SHA256
    - SL\_SEC\_MASK\_TLS\_DHE\_RSA\_WITH\_CHACHA20\_POLY1305\_SHA256
  - Server authentication
  - Client authentication
  - Domain name verification
  - Runtime socket upgrade to secure socket – STARTTLS
- Secure HTTP server (HTTPS)
- Trusted root-certificate catalog—Verifies that the CA used by the application is trusted and known secure content delivery
- TI root-of-trust public key—Hardware-based mechanism that allows authenticating TI as the genuine origin of a given content using asymmetric keys
- Secure content delivery—Allows encrypted file transfer to the system using asymmetric keys created by the device

**Code and Data Security:**

- Network passwords and certificates are encrypted and signed.
- Cloning protection—Application and data files are encrypted by a unique key per device.
- Access control—Access to application and data files only by using a token provided in file creation time. If an unauthorized access is detected, a tamper protection lockdown mechanism takes effect.
- Encrypted and Authenticated file system (not supported in CC3220R)
- Secured boot—Authentication of the application image on every boot
- Code and data encryption (not supported in CC3220R)—User application and data files are encrypted in sFlash.
- Code and data authentication (not supported in CC3220R)—User Application and data files are authenticated with a public key certificate.
- Offloaded crypto library for asymmetric keys, including the ability to create key-pair, sign and verify data buffer
- Recovery mechanism

**Device Security:**

- Separate execution environments—Application processor and network processor run on separate ARM cores
- Initial secure programming (not supported in CC3220R)—Allows for keeping the content confidential on the production line
- Debug security (not supported in CC3220R)
  - JTAG lock
  - Debug ports lock
- True random number generator

Figure 5-2 shows the high-level structure of the CC3220R device. The network information files (passwords and certificates) are encrypted using a device-specific key.

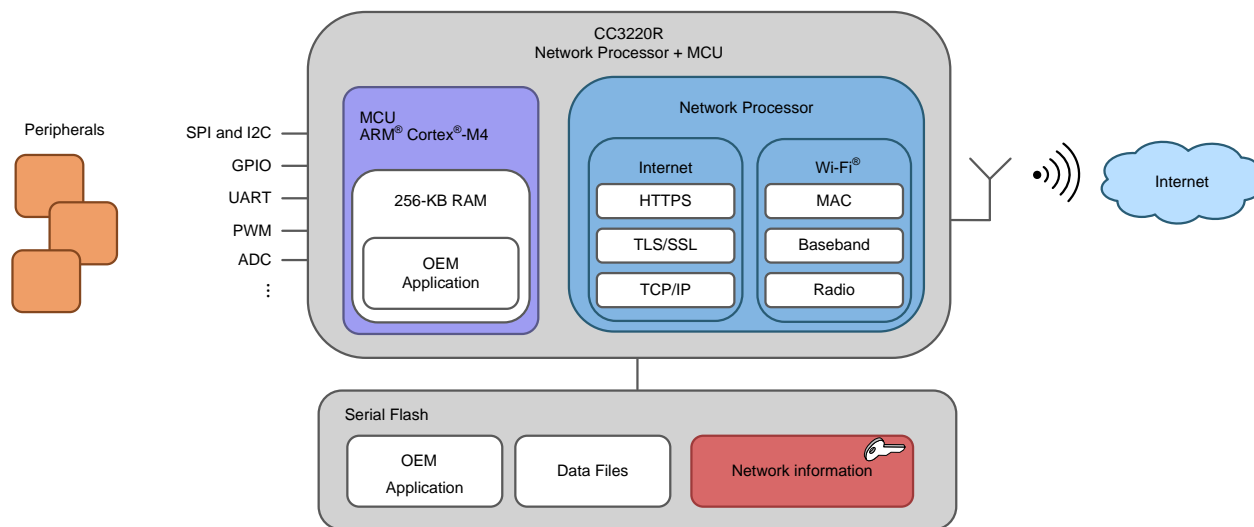

Copyright © 2017, Texas Instruments Incorporated

**Figure 5-2. CC3220R High-Level Structure**

Figure 5-3 shows the high-level structure of the CC3220S and CC3220SF devices. The application image, user data, and network information files (passwords, certificates) are encrypted using a device-specific key.

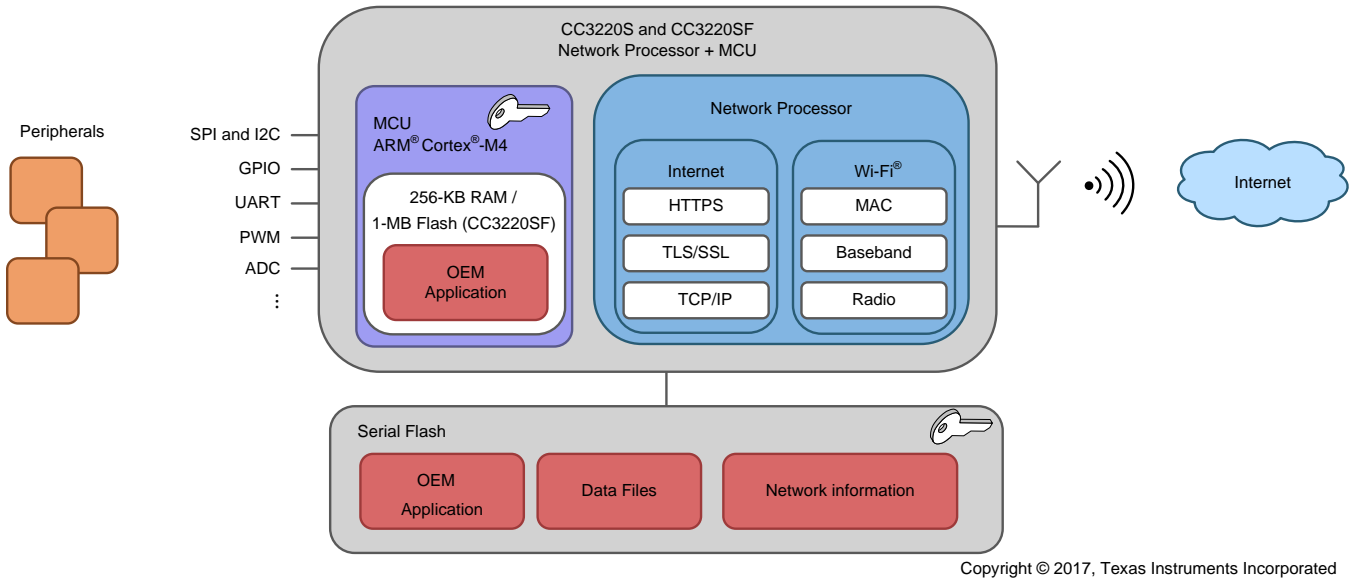

**Figure 5-3. CC3220S and CC3220SF High-Level Structure**

## 5.6 Power-Management Subsystem

The CC3220x power-management subsystem contains DC-DC converters to accommodate the different voltage or current requirements of the system.

- Digital DC-DC (Pin 44)
  - Input: VBAT wide voltage (2.1 to 3.6 V) or preregulated 1.85 V
- ANA1 DC-DC (Pin 37)
  - Input: VBAT wide voltage (2.1 to 3.6 V)
  - In preregulated 1.85-V mode, the ANA1 DC-DC converter is bypassed.
- PA DC-DC (Pin 39)
  - Input: VBAT wide voltage (2.1 to 3.6 V)
  - In preregulated 1.85-V mode, the PA DC-DC converter is bypassed.
- ANA2 DC-DC (Pin 47)
  - Input: VBAT wide voltage (2.1 to 3.6 V) or preregulated 1.85 V

The CC3220x device is a single-chip WLAN radio solution used on an embedded system with a wide-voltage supply range. The internal power management, including DC-DC converters and LDOs, generates all of the voltages required for the device to operate from a wide variety of input sources. For maximum flexibility, the device can operate in the modes described in [Section 5.6.1](#) and [Section 5.6.2](#).

### 5.6.1 VBAT Wide-Voltage Connection

In the wide-voltage battery connection, the device is powered directly by the battery or preregulated 3.3-V supply. All other voltages required to operate the device are generated internally by the DC-DC converters. This scheme supports wide-voltage operation from 2.1 to 3.6 V and is thus the most common mode for the device.

### 5.6.2 Preregulated 1.85-V Connection

The preregulated 1.85-V mode of operation applies an external regulated 1.85 V directly at pins 10, 25, 33, 36, 37, 39, 44, 48, and 54 of the device. The VBAT and the VIO are also connected to the 1.85-V supply. This mode provides the lowest BOM count version in which inductors used for PA DC-DC and ANA1 DC-DC (2.2 and 1  $\mu$ H) and a capacitor (22  $\mu$ F) can be avoided.

In the preregulated 1.85-V mode, the regulator providing the 1.85 V must have the following characteristics:

- Load current capacity  $\geq 900$  mA
- Line and load regulation with  $< 2\%$  ripple with 500-mA step current and settling time of  $< 4$   $\mu$ s with the load step

#### NOTE

The regulator must be placed as close as possible to the device so that the IR drop to the device is very low.

### 5.7 Low-Power Operating Mode

From a power-management perspective, the CC3220x device comprises the following two independent subsystems:

- Cortex-M4 application processor subsystem
- Networking subsystem

Each subsystem operates in one of several power states.

The Cortex-M4 application processor runs the user application loaded from an external serial flash, or internal flash (in CC3220SF). The networking subsystem runs preprogrammed TCP/IP and Wi-Fi data link layer functions.

The user program controls the power state of the application processor subsystem and can be in one of the five modes described in [Table 5-2](#).

**Table 5-2. User Program Modes**

APPLICATION PROCESSOR (MCU) MODE <sup>(1)</sup>	DESCRIPTION
MCU active mode	MCU executing code at 80-MHz state rate
MCU sleep mode	The MCU clocks are gated off in sleep mode and the entire state of the device is retained. Sleep mode offers instant wakeup. The MCU can be configured to wake up by an internal fast timer or by activity from any GPIO line or peripheral.
MCU LPDS mode	State information is lost and only certain MCU-specific register configurations are retained. The MCU can wake up from external events or by using an internal timer. (The wake-up time is less than 3 ms.) Certain parts of memory can be retained while the MCU is in LPDS mode. The amount of memory retained is configurable. Users can choose to preserve code and the MCU-specific setting. The MCU can be configured to wake up using the RTC timer or by an external event on specific GPIOs defined as the wake-up source.
MCU hibernate mode	The lowest power mode in which all digital logic is power-gated. Only a small section of the logic directly powered by the input supply is retained. The RTC keeps running and the MCU supports wakeup from an external event or from an RTC timer expiry. Wake-up time is longer than LPDS mode at about 15 ms plus the time to load the application from serial flash, which varies according to code size. In this mode, the MCU can be configured to wake up using the RTC timer or external event on a GPIO.
MCU shutdown mode	The lowest power mode system-wide. All device logics are off, including the RTC. The wake-up time in this mode is longer than hibernate at about 1.1 s. To enter or exit the shutdown mode, the state of the nRESET line is changed (low to shut down, high to turn on).

(1) Modes are listed in order of power consumption, with highest power modes listed first.

The NWP can be active or in LPDS mode and takes care of its own mode transitions. When there is no network activity, the NWP sleeps most of the time and wakes up only for beacon reception (see [Table 5-3](#)).

**Table 5-3. Networking Subsystem Modes**

NETWORK PROCESSOR MODE	DESCRIPTION
Network active mode (processing layer 3, 2, and 1)	Transmitting or receiving IP protocol packets
Network active mode (processing layer 2 and 1)	Transmitting or receiving MAC management frames; IP processing not required.
Network active listen mode	Special power optimized active mode for receiving beacon frames (no other frames supported)
Network connected Idle	A composite mode that implements 802.11 infrastructure power save operation. The CC3220x NWP automatically goes into LPDS mode between beacons and then wakes to active listen mode to receive a beacon and determine if there is pending traffic at the AP. If not, the NWP returns to LPDS mode and the cycle repeats.
Network LPDS mode	Low-power state between beacons in which the state is retained by the NWP, allowing for a rapid wake up.
Network disabled	The network is disabled

The operation of the application and network processor ensures that the device remains in the lowest power mode most of the time to preserve battery life.

The following examples show the use of the power modes in applications:

- A product that is continuously connected to the network in the 802.11 infrastructure power-save mode but sends and receives little data spends most of the time in connected idle, which is a composite of receiving a beacon frame and waiting for the next beacon.
- A product that is not continuously connected to the network but instead wakes up periodically (for example, every 10 minutes) to send data, spends most of the time in hibernate mode, jumping briefly to active mode to transmit data.

## 5.8 Memory

### 5.8.1 External Memory Requirements

The CC3220x device maintains a proprietary file system on the sFLASH. The CC3220x file system stores the MCU binary, service pack file, system files, configuration files, certificate files, web page files, and user files. By using a format command through the API, users can provide the total size allocated for the file system. The starting address of the file system cannot be set and is always at the beginning of the sFLASH. The applications microcontroller must access the sFLASH memory area allocated to the file system directly through the CC3220x file system. The applications microcontroller must not access the sFLASH memory area directly.

The file system manages the allocation of sFLASH blocks for stored files according to download order, which means that the location of a specific file is not fixed in all systems. Files are stored on sFLASH using human-readable filenames rather than file IDs. The file system API works using plain text, and file encryption and decryption is invisible to the user. Encrypted files can be accessed only through the file system.

All file types can have a maximum of 100 supported files in the file system. All files are stored in 4-KB blocks and thus use a minimum of 4KB of flash space. Fail-safe files require twice the original size and use a minimum of 8KB. Encrypted files are counted as fail-safe in terms of space. The maximum file size is 1MB.

Table 5-4 lists the minimum required memory consumption under the following assumptions:

- System files in use consume 64 blocks (256KB).
- Vendor files are not taken into account.
- MCU code is taken as the maximal possible size for the CC3220 with fail-safe enabled to account for future updates, such as through OTA.
- Gang image:
  - Storage for the gang image is rounded up to 32 blocks (meaning 128-KB resolution).
  - Gang image size depends on the actual content size of all components. Additionally, the image should be 128-KB aligned so unaligned memory is considered lost. Service pack, system files, and the 128-KB aligned memory are assumed to occupy 256KB.
- All calculations consider that the restore-to-default is enabled.

**Table 5-4. Recommended Flash Size**

ITEM	CC3220R and CC3220S [KB]	CC3220SF [KB]
File system allocation table	20	20
System and configuration files <sup>(1)</sup>	256	256
Service Pack <sup>(1)</sup>	264	264
MCU Code <sup>(1)</sup>	512	2048
Gang image size	256 + MCU	256 + MCU
Total	1308 + MCU	2844 + MCU
Minimal flash size <sup>(2)</sup>	16MBit	32MBit
Recommended flash size <sup>(2)</sup>	16MBit	32MBit

(1) Including fail-safe.

(2) For maximum MCU size.

#### NOTE

The maximum supported sFLASH size is 32MB (256Mb). Please refer to [Using Serial Flash on CC3120/CC3220 SimpleLink™ Wi-Fi® and Internet-of-Things Devices](#).

## 5.8.2 Internal Memory

The CC3220x device includes on-chip SRAM to which application programs are downloaded and executed. The application developer must share the SRAM for code and data. The micro direct memory access ( $\mu$ DMA) controller can transfer data to and from SRAM and various peripherals. The CC3220x ROM holds the rich set of peripheral drivers, which saves SRAM space. For more information on drivers, see the CC3220x API list.

### 5.8.2.1 SRAM

The CC3220x family provides 256KB of on-chip SRAM. Internal RAM is capable of selective retention during LPDS mode. This internal SRAM is at offset 0x2000 0000 of the device memory map.

Use the  $\mu$ DMA controller to transfer data to and from the SRAM.

When the device enters low-power mode, the application developer can choose to retain a section of memory based on need. Retaining the memory during low-power mode provides a faster wakeup. The application developer can choose the amount of memory to retain in multiples of 64KB. For more information, see the API guide.

### 5.8.2.2 ROM

The internal zero-wait-state ROM of the CC3220x device is at address 0x0000 0000 of the device memory and is programmed with the following components:

- Bootloader
- Peripheral driver library (DriverLib) release for product-specific peripherals and interfaces

The bootloader is used as an initial program loader (when the serial flash memory is empty). The CC3220x DriverLib software library controls on-chip peripherals with a bootloader capability. The library performs peripheral initialization and control functions, with a choice of polled or interrupt-driven peripheral support. The DriverLib APIs in ROM can be called by applications to reduce flash memory requirements and free the flash memory for other purposes.

### 5.8.2.3 Flash Memory

The CC3220SF device comes with an on-chip flash memory of 1MB that allows application code to execute in place while freeing SRAM exclusively for read-write data. The flash memory is used for code and constant data sections and is directly attached to the ICODE/DCODE bus of the Cortex-M4 core. A 128-bit-wide instruction prefetch buffer allows maintenance of maximum performance for linear code or loops that fit inside the buffer.

The flash memory is organized as 2-KB sectors that can be independently erased. Reads and writes can be performed at word (32-bit) level.

### 5.8.2.4 Memory Map

Table 5-5 describes the various MCU peripherals and how they are mapped to the processor memory. For more information on peripherals, see the API document.

**Table 5-5. Memory Map**

START ADDRESS	END ADDRESS	DESCRIPTION	COMMENT
0x0000 0000	0x0007 FFFF	On-chip ROM (bootloader + DriverLib)	
0x0100 0000	0x010F FFFF	On-chip flash (for user application code)	CC3220FS device only
0x2000 0000	0x2003 FFFF	Bit-banded on-chip SRAM	
0x2200 0000	0x23FF FFFF	Bit-band alias of 0x2000 0000 to 0x200F FFFF	
0x4000 0000	0x4000 0FFF	Watchdog timer A0	
0x4000 4000	0x4000 4FFF	GPIO port A0	
0x4000 5000	0x4000 5FFF	GPIO port A1	
0x4000 6000	0x4000 6FFF	GPIO port A2	
0x4000 7000	0x4000 7FFF	GPIO port A3	
0x4000 C000	0x4000 CFFF	UART A0	
0x4000 D000	0x4000 DFFF	UART A1	
0x4002 0000	0x4000 07FF	I <sup>2</sup> C A0 (master)	
0x4002 4000	0x4002 4FFF	GPIO group 4	
0x4002 0800	0x4002 0FFF	I <sup>2</sup> C A0 (slave)	
0x4003 0000	0x4003 0FFF	General-purpose timer A0	
0x4003 1000	0x4003 1FFF	General-purpose timer A1	
0x4003 2000	0x4003 2FFF	General-purpose timer A2	
0x4003 3000	0x4003 3FFF	General-purpose timer A3	
0x400F7000	0x400F 7FFF	Configuration registers	
0x400F E000	0x400F EFFF	System control	
0x400F F000	0x400F FFFF	μDMA	
0x4200 0000	0x43FF FFFF	Bit band alias of 0x4000 0000 to 0x400F FFFF	
0x4401 0000	0x4401 0FFF	SDIO master	
0x4401 8000	0x4401 8FFF	Camera Interface	
0x4401 C000	0x4401 EFFF	McASP	
0x4402 0000	0x4402 0FFF	SSPI	Used for external serial flash
0x4402 1000	0x4402 2FFF	GSPI	Used by application processor
0x4402 5000	0x4402 5FFF	MCU reset clock manager	
0x4402 6000	0x4402 6FFF	MCU configuration space	
0x4402 D000	0x4402 DFFF	Global power, reset, and clock manager (GPRCM)	
0x4402 E000	0x4402 EFFF	MCU shared configuration	
0x4402 F000	0x4402 FFFF	Hibernate configuration	
0x4403 0000	0x4403 FFFF	Crypto range (includes apertures for all crypto-related blocks as follows)	
0x4403 0000	0x4403 0FFF	DTHE registers and TCP checksum	
0x4403 5000	0x4403 5FFF	MD5/SHA	
0x4403 7000	0x4403 7FFF	AES	
0x4403 9000	0x4403 9FFF	DES	
0xE000 0000	0xE000 0FFF	Instrumentation trace Macrocell™	
0xE000 1000	0xE000 1FFF	Data watchpoint and trace (DWT)	
0xE000 2000	0xE000 2FFF	Flash patch and breakpoint (FPB)	
0xE000 E000	0xE000 EFFF	NVIC	
0xE004 0000	0xE004 0FFF	Trace port interface unit (TPIU)	

**Table 5-5. Memory Map (continued)**

START ADDRESS	END ADDRESS	DESCRIPTION	COMMENT
0xE004 1000	0xE004 1FFF	Reserved for embedded trace macrocell (ETM)	
0xE004 2000	0xE00F FFFF	Reserved	

## 5.9 Restoring Factory Default Configuration

The device has an internal recovery mechanism that allows rolling back the file system to its predefined factory image or restoring the factory default parameters of the device. The factory image is kept in a separate sector on the sFLASH in a secure manner and cannot be accessed from the host processor. The following restore modes are supported:

- None—no factory restore settings
- Enable restore of factory default parameters
- Enable restore of factory image and factory default parameters

The restore process is performed by calling SW APIs, or by pulling or forcing SOP[2:0] = 110 pins and toggling the nRESET pin from low to high.

The process is fail-safe and resumes operation if a power failure occurs before the restore is finished. The restore process typically takes about 8 seconds, depending on the attributes of the serial flash vendor.

## 5.10 Boot Modes

### 5.10.1 Boot Mode List

The CC3220x device implements a sense-on-power (SoP) scheme to determine the device operation mode.

SoP values are sensed from the device pin during power up. This encoding determines the boot flow. Before the device is taken out of reset, the SoP values are copied to a register and used to determine the device operation mode while powering up. These values determine the boot flow as well as the default mapping for some of the pins (JTAG, SWD, UART0). [Table 5-6](#) lists the pull configurations.

**Table 5-6. CC3220x Functional Configurations**

NAME	SOP[2]	SOP[1]	SOP[0]	SoP MODE	COMMENT
UARTLOAD	Pullup	Pulldown	Pulldown	LDfrUART	Factory, lab flash, and SRAM loads through the UART. The device waits indefinitely for the UART to load code. The SOP bits then must be toggled to configure the device in functional mode. Also puts JTAG in 4-wire mode.
FUNCTIONAL_2WJ	Pulldown	Pulldown	Pullup	Fn2WJ	Functional development mode. In this mode, 2-pin SWD is available to the developer. TMS and TCK are available for debugger connection.
FUNCTIONAL_4WJ	Pulldown	Pulldown	Pulldown	Fn4WJ	Functional development mode. In this mode, 4-pin JTAG is available to the developer. TDI, TMS, TCK, and TDO are available for debugger connection.
UARTLOAD_FUNCTIONAL_4WJ	Pulldown	Pullup	Pulldown	LDfrUART_Fn4WJ	Supports flash and SRAM load through UART and functional mode. The MCU bootloader tries to detect a UART break on UART receive line. If the break signal is present, the device enters the UARTLOAD mode, otherwise, the device enters the functional mode. TDI, TMS, TCK, and TDO are available for debugger connection.

**Table 5-6. CC3220x Functional Configurations (continued)**

NAME	SOP[2]	SOP[1]	SOP[0]	SoP MODE	COMMENT
RET_FACTORY_IMAGE	Pulldown	Pullup	Pullup	RetFactDef	When device reset is toggled, the MCU bootloader kickstarts the procedure to restore factory default images.

The recommended values of pull resistors are 100 kΩ for SOP0 and SOP1 and 2.7 kΩ for SOP2. The application can use SOP2 for other functions after chip has powered up. However, to avoid spurious SOP values from being sensed at power up, TI strongly recommends using the SOP2 pin only for output signals. The SOP0 and SOP1 pins are multiplexed with the WLAN analog test pins and are not available for other functions.

## 6 Applications, Implementation, and Layout

---

### NOTE

Information in the following Applications section is not part of the TI component specification, and TI does not warrant its accuracy or completeness. TI's customers are responsible for determining suitability of components for their purposes. Customers should validate and test their design implementation to confirm system functionality.

---

### 6.1 Application Information

#### 6.1.1 *Typical Application—CC3220x Wide-Voltage Mode*

Figure 6-1 shows the schematic for an application using the CC3220x device in the wide-voltage mode of operation. For a full operation reference design, refer to [CC3220 SimpleLink™ and Internet of Things Hardware Design Files](#).

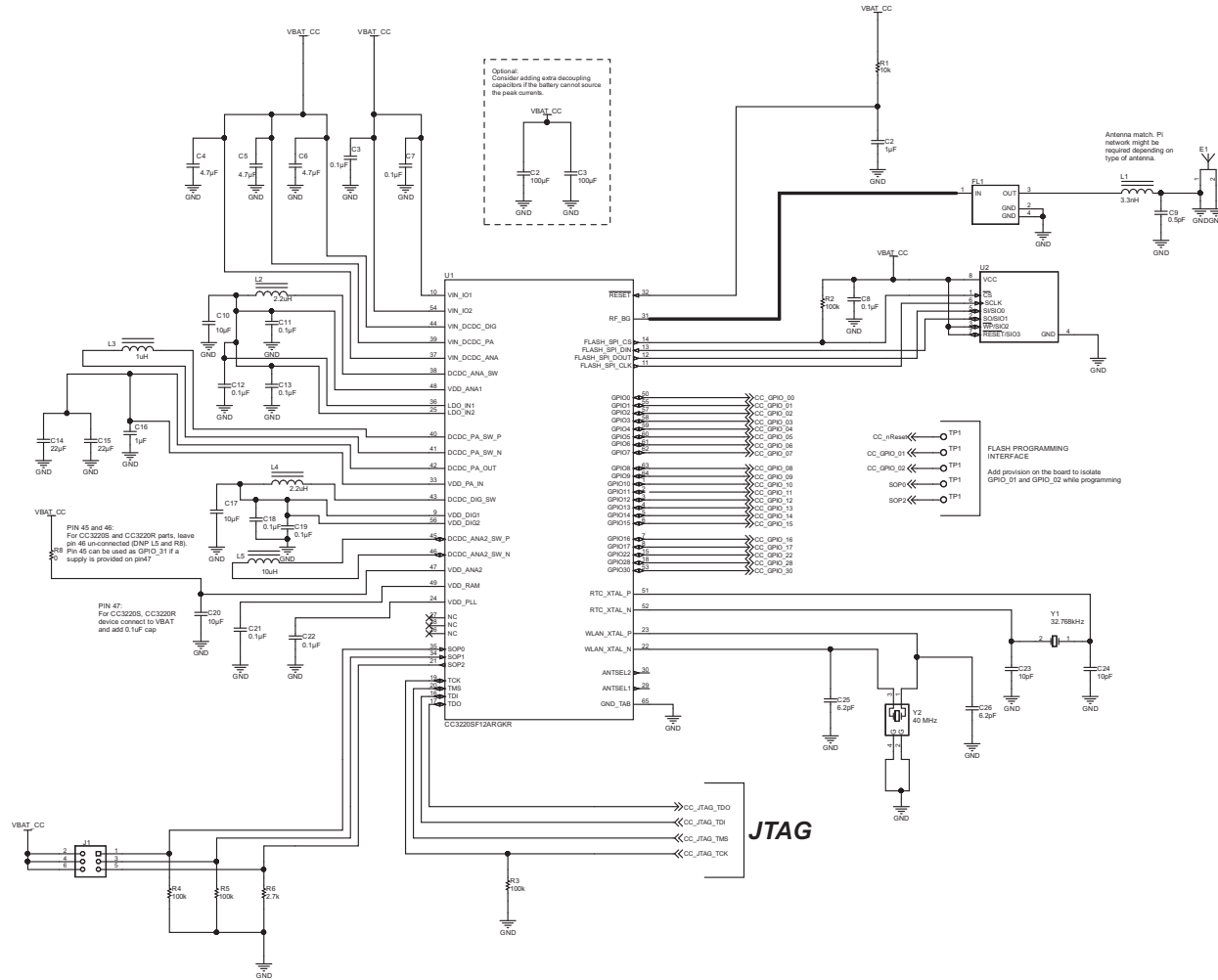

Figure 6-1. CC3220x Wide Voltage Mode Application Circuit

**NOTE**

For complete reference schematics and BOM, see the [CC3220x product page](#).

Table 6-1 lists the bill of materials for an application using the CC3220x device in wide-voltage mode.

**Table 6-1. Bill of Materials for CC3220x in Wide-Voltage Mode**

QUANTITY	PART REFERENCE	VALUE	MANUFACTURER	PART NUMBER	DESCRIPTION
1	C1	1 $\mu$ F	MuRata	GRM155R61A105KE15D	Capacitor, Ceramic, 1 $\mu$ F, 10 V, $\pm$ 10%, X5R, 0402
10	C2, C6, C10, C12, C13, C14, C19, C20, C22, C23	0.1 $\mu$ F	TDK	C1005X5R1A104K050BA	Capacitor, Ceramic, 0.1 $\mu$ F, 10 V, $\pm$ 10%, X5R, 0402
3	C3, C4, C5	4.7 $\mu$ F	TDK	C1005X5R0J475M050BC	Capacitor, Ceramic, 4.7 $\mu$ F, 6.3 V, $\pm$ 20%, X5R, 0402
2	C7, C8	100 $\mu$ F	Taiyo Yuden	LMK325ABJ107MMHT	Capacitor, Ceramic, 100 $\mu$ F, 10 V, $\pm$ 20%, X5R, AEC-Q200 Grade 3, 1210
1	C9	0.5 pF	MuRata	GRM1555C1HR50BA01D	Capacitor, Ceramic, 0.5 pF, 50 V, $\pm$ 20%, C0G/NP0, 0402
3	C11, C18, C21	10 $\mu$ F	MuRata	GRM188R60J106ME47D	Capacitor, Ceramic, 10 $\mu$ F, 6.3 V, $\pm$ 20%, X5R, 0603
1	C15	1 $\mu$ F	TDK	C1005X5R1A105K050BB	Capacitor, Ceramic, 1 $\mu$ F, 10 V, $\pm$ 10%, X5R, 0402
2	C16, C17	22 $\mu$ F	TDK	C1608X5R0G226M080AA	Capacitor, Ceramic, 22 $\mu$ F, 4 V, $\pm$ 20%, X5R, 0603
2	C24, C25	10 pF	MuRata	GRM1555C1H100JA01D	Capacitor, Ceramic, 10 pF, 50 V, $\pm$ 5%, C0G/NP0, 0402
2	C26, C27	6.2 pF	MuRata	GRM1555C1H6R2CA01D	Capacitor, Ceramic, 6.2 pF, 50 V, $\pm$ 5%, C0G/NP0, 0402
1	E1	2.45-GHz Antenna	Taiyo Yuden	AH316M245001-T	ANT BLUETOOTH W-LAN ZIGBEE WIMAX, SMD
1	FL1	1.02 dB	TDK	DEA202450BT-1294C1-H	Multilayer Chip Band Pass Filter For 2.4GHz W-LAN/Bluetooth, SMD
1	L1	3.3 nH	MuRata	LQG15HS3N3S02D	Inductor, Multilayer, Air Core, 3.3 nH, 0.3 A, 0.17 $\Omega$ , SMD
2	L2, L4	2.2 $\mu$ H	MuRata	LQM2HPN2R2MG0L	Inductor, Multilayer, Ferrite, 2.2 $\mu$ H, 1.3 A, 0.08 $\Omega$ , SMD
1	L3	1 $\mu$ H	MuRata	LQM2HPN1R0MG0L	Inductor, Multilayer, Ferrite, 1 $\mu$ H, 1.6 A, 0.055 $\Omega$ , SMD
1	L5	10 $\mu$ H	Taiyo Yuden	CBC2518T100M	Inductor, Wirewound, Ceramic, 10 $\mu$ H, 0.48 A, 0.36 $\Omega$ , SMD
1	R1	10 k	Vishay-Dale	CRCW040210K0JNED	RES, 10 k, 5%, 0.063 W, 0402
4	R2, R3, R4, R5	100 k	Vishay-Dale	CRCW0402100KJNED	RES, 100 k, 5%, 0.063 W, 0402
1	R6	2.7 k	Vishay-Dale	CRCW04022K70JNED	RES, 2.7 k, 5%, 0.063 W, 0402
1	U1	MX25R	Macronix International Co., LTD	MX25R3235FM11L0	Ultra-Low Power, 32-Mbit [x 1/x 2/x 4] CMOS MXSMIO (Serial Multi I/O) Flash Memory, SOP-8
1	U2	CC3200	Texas Instruments	CC3220SF12RGK	SimpleLink Wi-Fi and Internet-of-Things Solution, a Single-Chip Wireless MCU, RGK0064B
1	Y1	Crystal	Abracon Corporation	ABS07-32.768KHZ-9-T	Crystal, 32.768 KHz, 9PF, SMD
1	Y2	Crystal	Epson	Q24FA20H0039600	Crystal, 40 MHz, 8pF, SMD

### 6.1.2 Typical Application Schematic—CC3220x Preregulated, 1.85-V Mode

Figure 6-2 shows the typical application schematic using the CC3220x in preregulated, 1.85-V mode of operation. For addition information on this mode of operation please contact your TI representative.

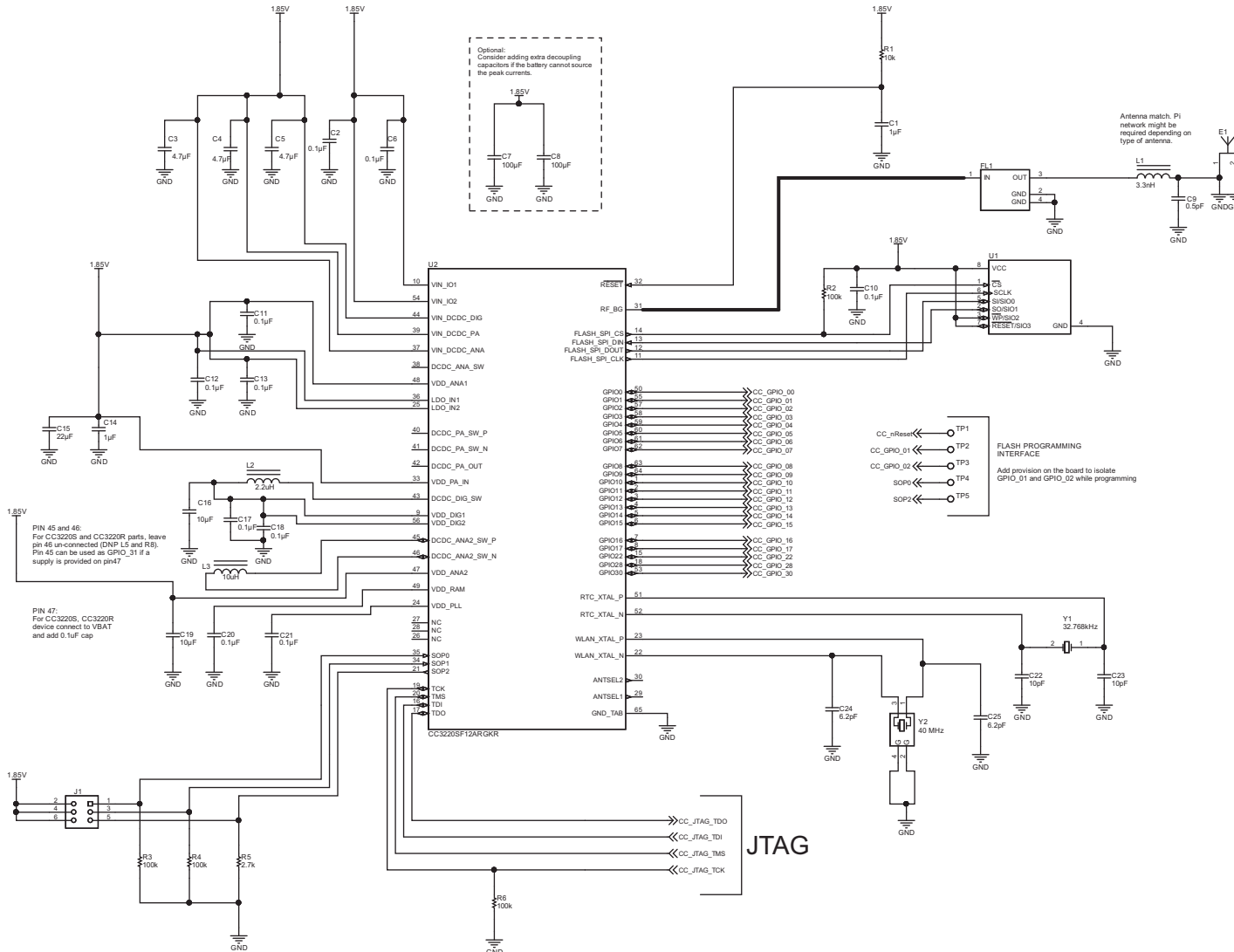

Figure 6-2. CC3220x Preregulated 1.85-V Mode Application Circuit

Table 6-2 lists the bill of materials for an application using the CC3120R device in preregulated 1.85-V mode.

**Table 6-2. Bill of Materials for CC3220x Preregulated, 1.85-V Mode**

QUANTITY	DESIGNATOR	VALUE	MANUFACTURER	PART NUMBER	DESCRIPTION
1	U1	MX25R	Macronix International Co. LTD	MX25R3235FM1IL0	Ultra-low power, 32-Mbit [x 1/x 2/x 4] CMOS MXSMIO (Serial Multi I/O) Flash Memory, SOP-8
1	U2	CC3220	Texas Instruments	CC3220SF12RGK	SimpleLink Wi-Fi and Internet-of-Things Solution, a Single-Chip Wireless MCU, RGK0064B
4	R2, R3, R4, R6	100 k	Vishay-Dale	CRCW0402100KJNED	RES, 100 k, 5%, 0.063 W, 0402
1	R1	10 k	Vishay-Dale	CRCW040210K0JNED	RES, 10 k, 5%, 0.063 W, 0402
1	R5	2.7 k	Vishay-Dale	CRCW04022K70JNED	RES, 2.7 k, 5%, 0.063 W, 0402
1	FL1	1.02 dB	TDK	DEA202450BT-1294C1-H	Multilayer Chip Band Pass Filter For 2.4GHz W-LAN/Bluetooth, SMD
1	L3	10 $\mu$ H	Taiyo Yuden	CBC2518T100M	Inductor, Wirewound, Ceramic, 10 $\mu$ H, 0.48 A, 0.36 ohm, SMD
1	L2	2.2 $\mu$ H	MuRata	LQM2HPN2R2MG0L	Inductor, Multilayer, Ferrite, 2.2 $\mu$ H, 1.3 A, 0.08 ohm, SMD
1	L1	3.3 nH	MuRata	LQG15HS3N3S02D	Inductor, Multilayer, Air Core, 3.3 nH, 0.3 A, 0.17 ohm, SMD
1	Y1	Crystal	Abracon Corporation	ABS07-32.768KHZ-9-T	Crystal, 32.768KHZ, 9PF, SMD
1	Y2	Crystal	Epson	Q24FA20H0039600	Crystal, 40MHz, 8pF, SMD
2	C7, C8	100 $\mu$ F	Taiyo Yuden	LMK325ABJ107MMHT	Capacitor, Ceramic, 100 $\mu$ F, 10 V, $\pm$ 20%, X5R, AEC-Q200 Grade 3, 1210
1	C15	22 $\mu$ F	TDK	C1608X5R0G226M080AA	Capacitor, Ceramic, 22 $\mu$ F, 4 V, $\pm$ 20%, X5R, 0603
2	C16, C19	10 $\mu$ F	MuRata	GRM188R60J106ME47D	Capacitor, Ceramic, 10 $\mu$ F, 6.3 V, $\pm$ 20%, X5R, 0603
2	C22, C23	10 pF	MuRata	GRM1555C1H100JA01D	Capacitor, Ceramic, 10 pF, 50 V, $\pm$ 5%, C0G/NP0, 0402
2	C24, C25	6.2 pF	MuRata	GRM1555C1H6R2CA01D	Capacitor, Ceramic, 6.2 pF, 50 V, $\pm$ 5%, C0G/NP0, 0402
3	C3, C4, C5	4.7 $\mu$ F	TDK	C1005X5R0J475M050BC	Capacitor, Ceramic, 4.7 $\mu$ F, 6.3 V, $\pm$ 20%, X5R, 0402
1	C1	1 $\mu$ F	MuRata	GRM155R61A105KE15D	Capacitor, Ceramic, 1 $\mu$ F, 10 V, $\pm$ 10%, X5R, 0402
1	C14	1 $\mu$ F	TDK	C1005X5R1A105K050BB	Capacitor, Ceramic, 1 $\mu$ F, 10 V, $\pm$ 10%, X5R, 0402
1	C9	0.5 pF	MuRata	GRM1555C1HR50BA01D	Capacitor, Ceramic, 0.5 pF, 50 V, $\pm$ 20%, C0G/NP0, 0402
10	C2, C6, C10, C11, C12, C13, C17, C18, C20, C21	0.1 $\mu$ F	TDK	C1005X5R1A104K050BA	Capacitor, Ceramic, 0.1 $\mu$ F, 10 V, $\pm$ 10%, X5R, 0402
1	E1	2.45 Ghz Antenna	Taiyo Yuden	AH316M245001-T	ANT Bluetooth W-LAN ZIGBEE WIMAX, SMD

## 6.2 PCB Layout Guidelines

This section details the PCB guidelines to speed up the PCB design using the CC3220x VQFN device. Follow these guidelines ensures that the design will minimize the risk with regulatory certifications including FCC, ETSI, and CE. For more information, see [CC3120 and CC3220 SimpleLink™ Wi-Fi® and IoT Solution Layout Guidelines](#).

### 6.2.1 General PCB Guidelines

Use the following PCB guidelines:

- Verify the recommended PCB stackup in the PCB design guidelines, as well as the recommended layers for signals and ground.
- Ensure that the QFN PCB footprint follows the information in [Section 8](#).
- Ensure that the QFN PCB GND and solder paste follow the recommendations provided in [CC3120 and CC3220 SimpleLink™ Wi-Fi® and IoT Solution Layout Guidelines](#).
- Decoupling capacitors must be as close as possible to the QFN device.

### 6.2.2 Power Layout and Routing

Three critical DC-DC converters must be considered for the CC3220x device.

- Analog DC-DC converter
- PA DC-DC converter
- Digital DC-DC converter

Each converter requires an external inductor and capacitor that must be laid out with care. DC current loops are formed when laying out the power components.

#### 6.2.2.1 Design Considerations

The following design guidelines must be followed when laying out the CC3220x device:

- Route all of the input decoupling capacitors (C11, C13, and C18) on L2 using thick traces, to isolate the RF ground from the noisy supply ground. This step is also required to meet the IEEE spectral mask specifications.
- Maintain the thickness of power traces to be greater than 12 mils. Take special consideration for power amplifier supply lines (pin 33, 40, 41, and 42), and all input supply pins (pin 37, 39, and 44).
- Ensure the shortest grounding loop for the PLL supply decoupling capacitor (pin 24).
- Place all decoupling capacitors as close to the respective pins as possible.
- Power budget: The CC3220x device can consume up to 450 mA for 3.3 V, 670 mA for 2.1 V, and 700 mA for 1.85 V, for 24 ms during the calibration cycle.
- Ensure the power supply is designed to source this current without any issues. The complete calibration (TX and RX) can take up to 17 mJ of energy from the battery over a time of 24 ms.
- The CC3220x device contains many high-current input pins. Ensure the trace feeding these pins is capable of handling the following currents:
  - PA DCDC input (pin 39) maximum 1 A
  - ANA DCDC input (pin 37) maximum 600 mA
  - DIG DCDC input (pin 44) maximum 500 mA
  - PA DCDC switching nodes (pin 40 and pin 41) maximum 1 A
  - PA DCDC output node (pin 42) maximum 1 A
  - ANA DCDC switching node (pin 38) maximum 600 mA
  - DIG DCDC switching node (pin 43) maximum 500 mA
  - PA supply (pin 33) maximum 500 mA

Figure 6-3 shows the ground routing for the input decoupling capacitors.

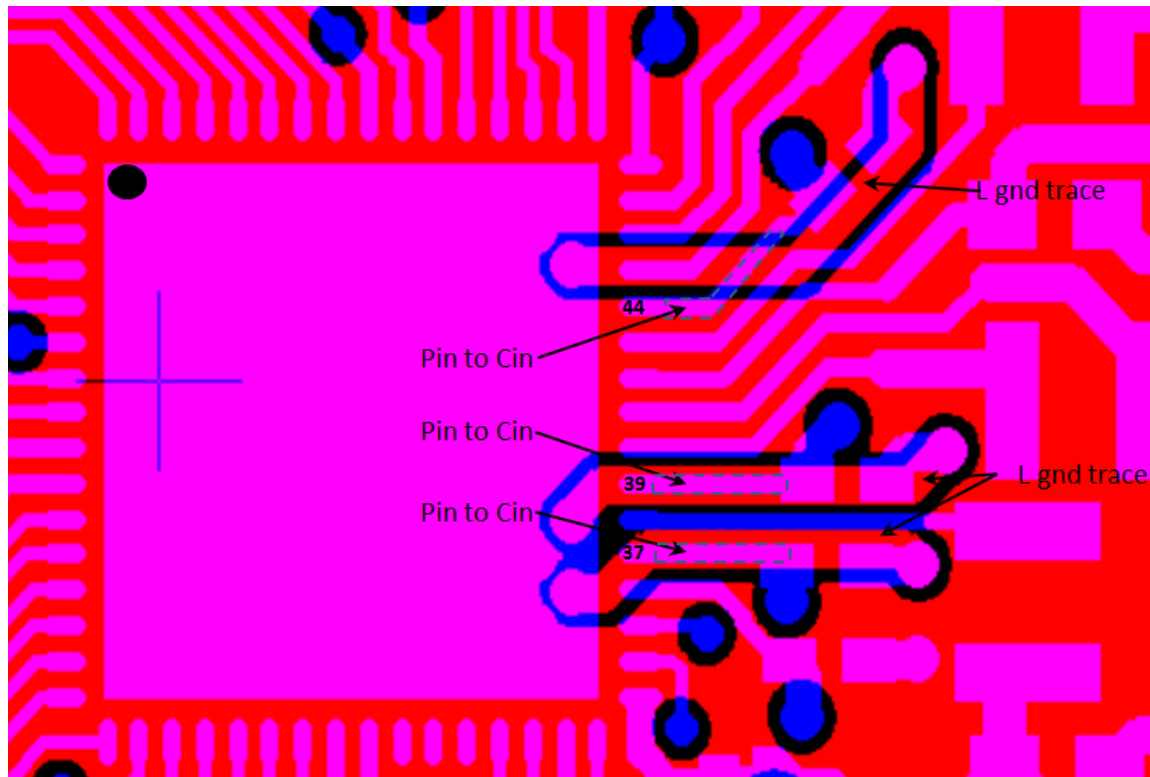

**Figure 6-3. Ground Routing for the Input Decoupling Capacitors**

The ground return for the input capacitors are routed on L2 to reduce the EMI and improve the spectral mask. This routing must be strictly followed because it is critical for the overall performance of the device.

### 6.2.3 Clock Interfaces

The following guidelines are for the slow clock.

- The 32.768-kHz crystal must be placed close to the QFN package.
- Ensure that the load capacitance is tuned according to the board parasitics to the frequency tolerance is within  $\pm 150$  ppm.
- The ground plane on layer two is solid below the trace lanes and there is ground around these traces on the top layer.

The following guidelines are for the fast clock.

- The 40-MHz crystal must be placed close to the QFN package.
- Ensure that the load capacitance is tuned according to the board parasitics to the frequency tolerance is within  $\pm 100$  ppm at room temperature. The total frequency across parts, temperature, and with aging, must be  $\pm 25$  ppm to meet the WLAN specification.
- Ensure that no high-frequency lines are routed close to the XTAL routing to avoid noise degradation.
- Ensure that crystal tuning capacitors are close to the crystal pads.
- Make both traces (XTALM and XTALP) as close to parallel as possible and approximately the same length.
- The ground plane on layer two is solid below the trace lines and that there is ground around these traces on the top layer.
- See [CC31xx & CC32xx Frequency Tuning](#) for frequency tuning.

### 6.2.4 Digital Input and Output

The following guidelines are for the digital I/O.

- Route SPI and UART lines away from any RF traces.
- Keep the length of the high-speed lines as short as possible to avoid transmission line effects.
- Keep the line lower than 1/10 of the rise time of the signal to ignore transmission line effects. This is required if the traces cannot be kept short. Place the resistor at the source end, closer to the device that is driving the signal.
- Add series-terminating resistor for each high-speed line (such as SPI\_CLK or SPI\_DATA) to match the driver impedance to the line. Typical terminating-resistor values range from 27 to 36  $\Omega$  for a 50- $\Omega$  line impedance.
- Route high-speed lines with a ground reference plane continuously below it to offer good impedance throughout. This routing also helps shield the trace against EMI.
- Avoid stubs on high-speed lines to minimize the reflections. If the line must be routed to multiple locations, use a separate line driver for each line.
- If the lines are longer compared to the rise time, add series-terminating resistors near the driver for each high-speed line to match the driver impedance to the line. Typical terminating-resistor values range from 27 to 36  $\Omega$  for a 50- $\Omega$  line impedance.

### 6.2.5 RF Interface

The following guidelines are for the RF interface. Follow guidelines specified in the vendor-specific antenna design guides (including placement of the antenna). Also see [CC3120 and CC3220 SimpleLink™ Wi-Fi® and IoT Solution Layout Guidelines](#) for general antenna guidelines.

- Ensure that the antenna is matched for 50- $\Omega$ . A Pi-matching network is recommended.
- Ensure that the area underneath the BPF pads are grounded on layer one and layer two, and that the minimum filter requirements are met.
- Verify that the Wi-Fi RF trace is a 50- $\Omega$ , impedance-controlled trace with a reference to solid ground.
- The RF trace bends must be made with gradual curves, and 90-degree bends must be avoided.
- The RF traces must not have sharp corners.
- There must be no traces or ground under the antenna section.
- The RF traces must have via stitching on the ground plane beside the RF trace on both sides.

## 7 Device and Documentation Support

TI offers an extensive line of development tools. Tools and software to evaluate the performance of the device, generate code, and develop solutions are listed in this section.

### 7.1 Tools and Software

#### Development Tools

**Pin Mux Tool** The supported devices are: CC3200 and CC3220x.

The Pin Mux Tool is a software tool that provides a graphical user interface (GUI) for configuring pin multiplexing settings, resolving conflicts and specifying I/O cell characteristics for MPUs from TI. Results are output as C header/code files that can be imported into software development kits (SDKs) or used to configure customers' custom software. Version 3 of the Pin Mux Tool adds the capability of automatically selecting a mux configuration that satisfies the entered requirements.

**SimpleLink Wi-Fi Radio Testing Tool** The supported devices are: CC3100, CC3200, and CC3220x.

The SimpleLink™ Wi-Fi® Radio Testing Tool is a Windows-based software tool for RF evaluation and testing of SimpleLink Wi-Fi CC31xx and CC32xx designs during development and certification. The tool enables low-level radio testing capabilities by manually setting the radio into transmit or receive modes. Using the tool requires familiarity and knowledge of radio circuit theory and radio test methods.

Created for the Internet of Things (IoT), the SimpleLink Wi-Fi CC31xx and CC32xx family of devices include on-chip Wi-Fi, Internet, and robust security protocols with no prior Wi-Fi experience needed for faster development. For more information on these devices, visit [SimpleLink™ Wi-Fi® family, Internet-on-a-chip™ solutions](#).

**SimpleLink Wi-Fi Starter Pro** The supported devices are: CC3100, CC3200, CC3120R, and CC3220x.

The SimpleLink™ Wi-Fi® Starter Pro mobile App is a new mobile application for SimpleLink provisioning. The app goes along with the embedded provisioning library and example that runs on the device side (can be found under SDKs [CC3120RSDK](#) and [CC3220SDK](#)). The new provisioning release is a TI recommendation for Wi-Fi provisioning using SimpleLink Wi-Fi products. The provisioning release implements advanced AP mode and SmartConfig™ technology provisioning with feedback and fallback options to ensure successful process has been accomplished. Customers can use both embedded library and the mobile library for integration to their end products.

**Image Creator** The supported devices are: CC3120R and CC3220x.

Image Creator is a web application which is used to create a programming image; it can also write the programming image into the SimpleLink CC3x20 devices. The programming image is a file which contains the SimpleLink device configurations and files required for the operation of the device. For the SimpleLink CC3220 wireless microcontroller, the Image Creator can also include the host application file. A new SimpleLink device should first be programmed by a programming image. The image, created by the Image Creator, can be programmed onto the device as part of the production procedure or when in development stage.

**CC3220 Software Development Kit (SDK)** The CC3220x device is supported.

The CC3220 SDK contains drivers, many sample applications for Wi-Fi features and Internet, as well as documentation needed to use the CC3220 Internet-on-a-chip solution. This SDK can be used with TI's MSP432P401R LaunchPad™ development kit, or with the SimpleLink Studio, a PC tool that allows MCU development with CC3220. You can also use the SDK as example code for any platform. All sample applications in the SDK are supported on TI's MSP432P401R ultra-low-power MCUs with Code Composer Studio™ IDE and TI-RTOS. In addition, many of the applications support IAR.

#### TI Designs and Reference Designs

The [TI Designs Reference Design Library](#) is a robust reference design library spanning analog, embedded processor, and connectivity. Created by TI experts to help you jumpstart your system design, all TI Designs include schematic or block diagrams, BOMs, and design files to speed your time to market.

## 7.2 Device Nomenclature

To designate the stages in the product development cycle, TI assigns prefixes to the part numbers of the CC3220x device and support tools (see [Figure 7-1](#)).

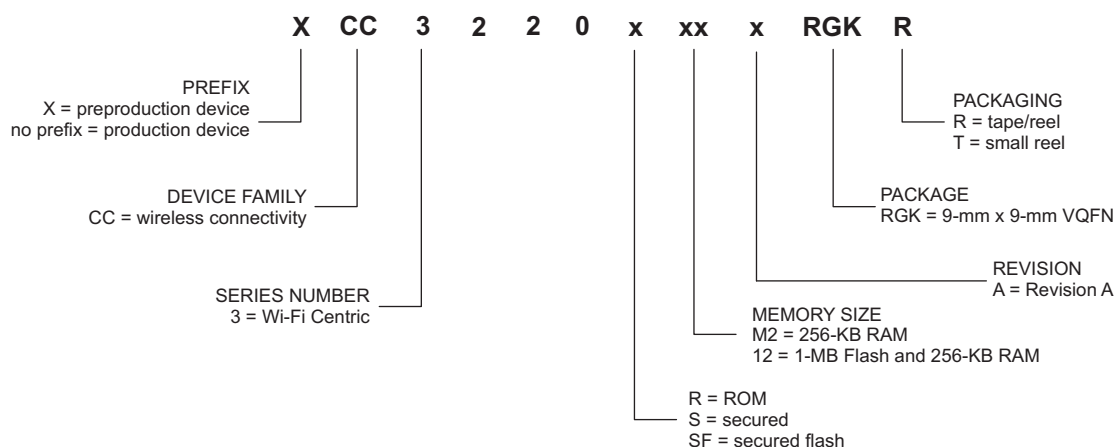

Figure 7-1. CC3220x Device Nomenclature

## 7.3 Documentation Support

To receive notification of documentation updates—including silicon errata—go to the product folder for your device on [ti.com](#) (CC3220). In the upper right corner, click the "Alert me" button. This registers you to receive a weekly digest of product information that has changed (if any). For change details, check the revision history of any revised document. The current documentation that describes the processor, related peripherals, and other technical collateral follows.

The following documents provide support for the CC3220 device.

### Errata

**CC3220R, CC3220S Silicon Errata** This document describes the known exceptions to the functional specifications for the CC3220R and the CC3220S SimpleLink™ Wi-Fi® Wireless and Internet-of-Things Solution, a Single-Chip Wireless MCU.

**CC3220SF Silicon Errata** This document describes the known exception to the functional specifications for the CC3220SF SimpleLink™ Wi-Fi® Wireless and Internet-of-Things Solution, a Single-Chip Wireless MCU.

### Application Reports

**SimpleLink™ CC3120, CC3220 Wi-Fi® Internet-on-a chip™ Networking Sub-System Power Management**

This application report describes the best practices for power management and extended battery life for embedded low-power Wi-Fi devices such as the SimpleLink Wi-Fi Internet-on-a chip™ solution from Texas Instruments™.

**SimpleLink™ CC3120, CC3220 Wi-Fi® Internet-on-a chip™ Solution Built-In Security Features** The SimpleLink Wi-Fi CC3120 and CC3220 Internet-on-a chip™ family of devices from Texas Instruments™ offer a wide range of built-in security features to help developers address a variety of security needs, which is achieved without any processing burden on the main microcontroller (MCU). This document describes these security-related features and provides recommendations for leveraging each in the context of practical system implementation.

**SimpleLink™ CC3120, CC3220 Wi-Fi® and Internet of Things Over-the-Air Update** This document describes the OTA library for the SimpleLink™ Wi-Fi® CC3x20 family of devices from Texas Instruments™ and explains how to prepare a new cloud-ready update to be downloaded by the OTA library.

**SimpleLink™ CC3120, CC3220 Wi-Fi® Internet-on-a chip™ Solution Device Provisioning** This guide describes the provisioning process, which provides the SimpleLink Wi-Fi device with the information (network name, password, and so forth) needed to connect to a wireless network.

**Using Serial Flash on SimpleLink™ CC3120 and CC3220 Wi-Fi® and Internet-of-Things Devices**

This application note is divided into two parts. The first part provides important guidelines and best-practice design techniques to consider when choosing and embedding a serial flash paired with the CC3120 and CC3220 (CC3x20) devices. The second part describes the file system, along with guidelines and considerations for system designers working with the CC3x20 devices.

## User's Guides

**SimpleLink™ Wi-Fi® and Internet of Things CC3120 and CC3220 Network Processor** This document provides software (SW) programmers with all of the required knowledge for working with the networking subsystem of the SimpleLink Wi-Fi devices. This guide provides basic guidelines for writing robust, optimized networking host applications, and describes the capabilities of the networking subsystem. The guide contains some example code snapshots, to give users an idea of how to work with the host driver. More comprehensive code examples can be found in the formal software development kit (SDK). This guide does not provide a detailed description of the host driver APIs.

**SimpleLink™ Wi-Fi® CC3120 and CC3220 and IoT Solution Layout Guidelines** This document provides the design guidelines of the 4-layer PCB used for the CC3120 and CC3220 SimpleLink Wi-Fi family of devices from Texas Instruments™. The CC3120 and CC3220 devices are easy to lay out and are available in quad flat no-leads (QFNs) packages. When designing the board, follow the suggestions in this document to optimize performance of the board.

**SimpleLink™ Wi-Fi® and Internet of Things Solution CC3220, a Single-Chip Wireless MCU** This guide is intended to assist users in the initial setup and demonstration of running their first sample application for the CC3220, CC3220S, CC3220SF SimpleLink™ Wi-Fi® and Internet of Things Solution, a Single-Chip Wireless MCU from Texas Instruments™. The guide explains how to install the software development kit (SDK) and various other tools required to get started with the first application.

**SimpleLink™ CC3220 Wi-Fi® LaunchPad™ Development Kit Hardware** The CC3220 SimpleLink LaunchPad™ Development Kit (CC3220-LAUNCHXL) is a low-cost evaluation platform for ARM® Cortex®-M4-based MCUs. The LaunchPad design highlights the CC3220 Internet-on-a chip™ solution and Wi-Fi capabilities. The CC3220 LaunchPad also features temperature and accelerometer sensors, programmable user buttons, three LEDs for custom applications, and onboard emulation for debugging. The stackable headers of the CC3220 LaunchPad XL interface demonstrate how easy it is to expand the functionality of the LaunchPad when interfacing with other peripherals on many existing BoosterPack™ Plug-in Module add-on boards, such as graphical displays, audio codecs, antenna selection, environmental sensing, and more.

**SimpleLink™ Wi-Fi® and Internet of Things CC3220** This document introduces the user to the environment setup for the CC3220x device, along with some reference examples from the software development kit (SDK). This document explains both the platform and the framework available to enable further application development.

**SimpleLink™ Wi-Fi® CC3220 Out-of-Box Application** This guide demonstrates the out-of-box experience for the CC3220 LaunchPad™ Development Kit, highlighting the easy connection to the CC3220 LaunchPad using the SimpleLink™ Wi-Fi® Starter Pro application, and the over-the-air update.

**SimpleLink™ Wi-Fi® and Internet-on-a-chip™ CC3120 and CC3220 Solution Radio Tool** The Radio Tool serves as a control panel for direct access to the radio, and can be used for both the radio frequency (RF) evaluation and for certification purposes. This guide describes how to have the tool work seamlessly on Texas Instruments™ evaluation platforms such as the BoosterPack™ plus FTDI emulation board for CC3120 devices, and the LaunchPad™ for CC3220 devices.

**SimpleLink™ Wi-Fi® CC3120 and CC3220 Provisioning for Mobile Applications** This guide describes TI's SimpleLink™ Wi-Fi® provisioning solution for mobile applications, specifically on the usage of the Android™ and iOS® building blocks for UI requirements, networking, and provisioning APIs required for building the mobile application.

**[SimpleLink™ Wi-Fi® CC3220 Out-of-Box Application](#)** This guide details the out-of-box (OOB) experience with the CC3220 LaunchPad™ Development Kit from Texas Instruments™.

#### More Literature

**[CC3220, CC3220S, CC3220SF SimpleLink™ Wi-Fi® and Internet of Things](#)** This document is the technical reference manual for the CC3220 device.

#### **[RemoTI Manifest](#)**

**[CC3220 SimpleLink™ Wi-Fi® and Internet of Things](#)** CC3220 hardware design files.

## 7.4 Community Resources

The following links connect to TI community resources. Linked contents are provided "AS IS" by the respective contributors. They do not constitute TI specifications and do not necessarily reflect TI's views; see TI's [Terms of Use](#).

**[TI E2E™ Online Community](#)** The TI engineer-to-engineer (E2E) community was created to foster collaboration among engineers. At [e2e.ti.com](http://e2e.ti.com), you can ask questions, share knowledge, explore ideas and help solve problems with fellow engineers.

**[TI Embedded Processors Wiki](#)** Established to help developers get started with Embedded Processors from Texas Instruments and to foster innovation and growth of general knowledge about the hardware and software surrounding these devices.

## 7.5 Trademarks

SimpleLink, Internet-on-a-chip, SmartConfig, Texas Instruments, E2E, LaunchPad, Code Composer Studio are trademarks of Texas Instruments.

ARM, Cortex, Thumb are registered trademarks of ARM Ltd.

Bluetooth is a registered trademark of Bluetooth SIG, Inc.

Macrocell is a trademark of Kappa Global Inc.

Wi-Fi CERTIFIED is a trademark of Wi-Fi Alliance.

Wi-Fi, Wi-Fi Direct are registered trademarks of Wi-Fi Alliance.

All other trademarks are the property of their respective owners.

## 7.6 Electrostatic Discharge Caution



This integrated circuit can be damaged by ESD. Texas Instruments recommends that all integrated circuits be handled with appropriate precautions. Failure to observe proper handling and installation procedures can cause damage.

ESD damage can range from subtle performance degradation to complete device failure. Precision integrated circuits may be more susceptible to damage because very small parametric changes could cause the device not to meet its published specifications.

## 7.7 Export Control Notice

Recipient agrees to not knowingly export or re-export, directly or indirectly, any product or technical data (as defined by the U.S., EU, and other Export Administration Regulations) including software, or any controlled product restricted by other applicable national regulations, received from disclosing party under nondisclosure obligations (if any), or any direct product of such technology, to any destination to which such export or re-export is restricted or prohibited by U.S. or other applicable laws, without obtaining prior authorization from U.S. Department of Commerce and other competent Government authorities to the extent required by those laws.

## 7.8 Glossary

[TI Glossary](#) This glossary lists and explains terms, acronyms, and definitions.

## 8 Mechanical, Packaging, and Orderable Information

The following pages include mechanical, packaging, and orderable information. This information is the most current data available for the designated devices. This data is subject to change without notice and revision of this document. For browser-based versions of this data sheet, refer to the left-hand navigation.

**PACKAGING INFORMATION**

Orderable Device	Status (1)	Package Type	Package Drawing	Pins	Package Qty	Eco Plan (2)	Lead/Ball Finish (6)	MSL Peak Temp (3)	Op Temp (°C)	Device Marking (4/5)	Samples
CC3220RM2ARGKR	ACTIVE	VQFN	RGK	64	2500	Green (RoHS & no Sb/Br)	CU NIPDAU   CU NIPDAUAG	Level-3-260C-168 HR	-40 to 85	CC3220R M2A	<a href="#">Samples</a>
CC3220RM2ARGKT	ACTIVE	VQFN	RGK	64	250	Green (RoHS & no Sb/Br)	CU NIPDAU   CU NIPDAUAG	Level-3-260C-168 HR	-40 to 85	CC3220R M2A	<a href="#">Samples</a>
CC3220SF12ARGKR	ACTIVE	VQFN	RGK	64	2500	Green (RoHS & no Sb/Br)	CU NIPDAU   CU NIPDAUAG	Level-3-260C-168 HR	-40 to 85	CC3220SF 12A	<a href="#">Samples</a>
CC3220SF12ARGKT	ACTIVE	VQFN	RGK	64	250	Green (RoHS & no Sb/Br)	CU NIPDAU   CU NIPDAUAG	Level-3-260C-168 HR	-40 to 85	CC3220SF 12A	<a href="#">Samples</a>
CC3220SM2ARGKR	ACTIVE	VQFN	RGK	64	2500	Green (RoHS & no Sb/Br)	CU NIPDAU   CU NIPDAUAG	Level-3-260C-168 HR	-40 to 85	CC3220S M2A	<a href="#">Samples</a>
CC3220SM2ARGKT	ACTIVE	VQFN	RGK	64	250	Green (RoHS & no Sb/Br)	CU NIPDAU   CU NIPDAUAG	Level-3-260C-168 HR	-40 to 85	CC3220S M2A	<a href="#">Samples</a>

(1) The marketing status values are defined as follows:

**ACTIVE:** Product device recommended for new designs.

**LIFEBUY:** TI has announced that the device will be discontinued, and a lifetime-buy period is in effect.

**NRND:** Not recommended for new designs. Device is in production to support existing customers, but TI does not recommend using this part in a new design.

**PREVIEW:** Device has been announced but is not in production. Samples may or may not be available.

**OBSOLETE:** TI has discontinued the production of the device.

(2) Eco Plan - The planned eco-friendly classification: Pb-Free (RoHS), Pb-Free (RoHS Exempt), or Green (RoHS & no Sb/Br) - please check <http://www.ti.com/productcontent> for the latest availability information and additional product content details.

**TBD:** The Pb-Free/Green conversion plan has not been defined.

**Pb-Free (RoHS):** TI's terms "Lead-Free" or "Pb-Free" mean semiconductor products that are compatible with the current RoHS requirements for all 6 substances, including the requirement that lead not exceed 0.1% by weight in homogeneous materials. Where designed to be soldered at high temperatures, TI Pb-Free products are suitable for use in specified lead-free processes.

**Pb-Free (RoHS Exempt):** This component has a RoHS exemption for either 1) lead-based flip-chip solder bumps used between the die and package, or 2) lead-based die adhesive used between the die and leadframe. The component is otherwise considered Pb-Free (RoHS compatible) as defined above.

**Green (RoHS & no Sb/Br):** TI defines "Green" to mean Pb-Free (RoHS compatible), and free of Bromine (Br) and Antimony (Sb) based flame retardants (Br or Sb do not exceed 0.1% by weight in homogeneous material)

(3) MSL, Peak Temp. - The Moisture Sensitivity Level rating according to the JEDEC industry standard classifications, and peak solder temperature.

(4) There may be additional marking, which relates to the logo, the lot trace code information, or the environmental category on the device.

(5) Multiple Device Markings will be inside parentheses. Only one Device Marking contained in parentheses and separated by a "~" will appear on a device. If a line is indented then it is a continuation of the previous line and the two combined represent the entire Device Marking for that device.

<sup>(6)</sup> Lead/Ball Finish - Orderable Devices may have multiple material finish options. Finish options are separated by a vertical ruled line. Lead/Ball Finish values may wrap to two lines if the finish value exceeds the maximum column width.

**Important Information and Disclaimer:** The information provided on this page represents TI's knowledge and belief as of the date that it is provided. TI bases its knowledge and belief on information provided by third parties, and makes no representation or warranty as to the accuracy of such information. Efforts are underway to better integrate information from third parties. TI has taken and continues to take reasonable steps to provide representative and accurate information but may not have conducted destructive testing or chemical analysis on incoming materials and chemicals. TI and TI suppliers consider certain information to be proprietary, and thus CAS numbers and other limited information may not be available for release.

In no event shall TI's liability arising out of such information exceed the total purchase price of the TI part(s) at issue in this document sold by TI to Customer on an annual basis.

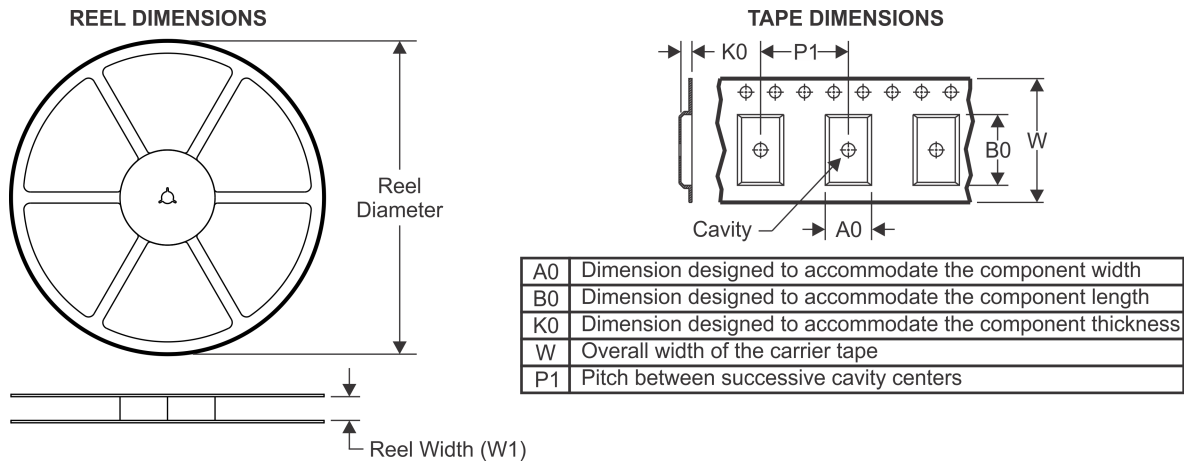
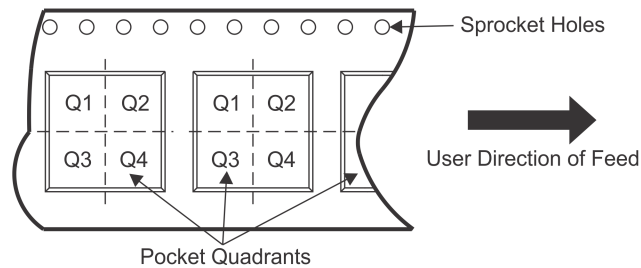
**TAPE AND REEL INFORMATION**

**QUADRANT ASSIGNMENTS FOR PIN 1 ORIENTATION IN TAPE**

\*All dimensions are nominal

Device	Package Type	Package Drawing	Pins	SPQ	Reel Diameter (mm)	Reel Width W1 (mm)	A0 (mm)	B0 (mm)	K0 (mm)	P1 (mm)	W (mm)	Pin1 Quadrant
CC3220RM2ARGKR	VQFN	RGK	64	2500	330.0	16.4	9.3	9.3	1.1	12.0	16.0	Q2
CC3220RM2ARGKT	VQFN	RGK	64	250	180.0	16.4	9.3	9.3	1.1	12.0	16.0	Q2
CC3220SF12ARGKR	VQFN	RGK	64	2500	330.0	16.4	9.3	9.3	1.1	12.0	16.0	Q2
CC3220SF12ARGKT	VQFN	RGK	64	250	180.0	16.4	9.3	9.3	1.1	12.0	16.0	Q2
CC3220SM2ARGKR	VQFN	RGK	64	2500	330.0	16.4	9.3	9.3	1.1	12.0	16.0	Q2
CC3220SM2ARGKT	VQFN	RGK	64	250	180.0	16.4	9.3	9.3	1.1	12.0	16.0	Q2

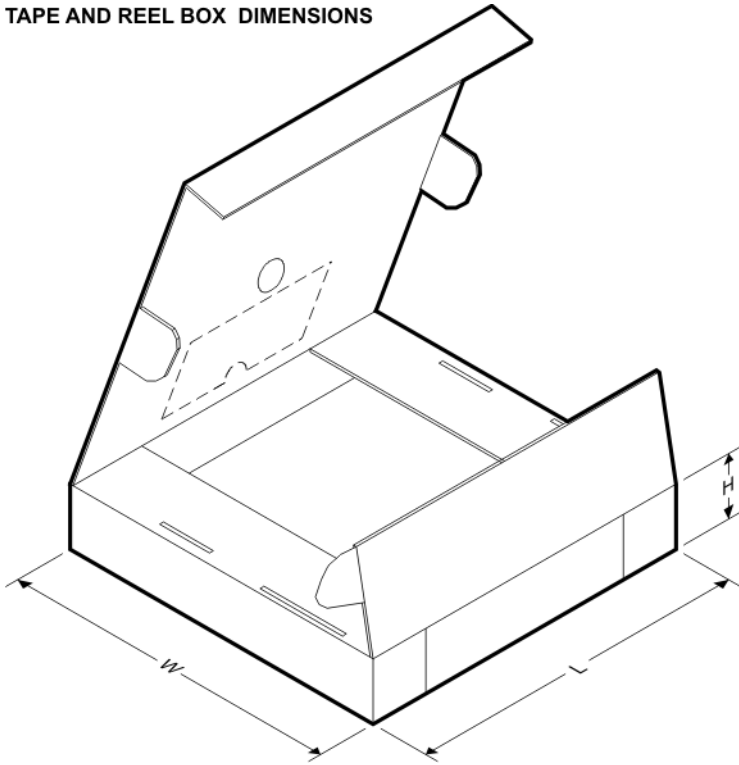
## TAPE AND REEL BOX DIMENSIONS



\*All dimensions are nominal

Device	Package Type	Package Drawing	Pins	SPQ	Length (mm)	Width (mm)	Height (mm)
CC3220RM2ARGKR	VQFN	RGK	64	2500	367.0	367.0	38.0
CC3220RM2ARGKT	VQFN	RGK	64	250	210.0	185.0	35.0
CC3220SF12ARGKR	VQFN	RGK	64	2500	367.0	367.0	38.0
CC3220SF12ARGKT	VQFN	RGK	64	250	210.0	185.0	35.0
CC3220SM2ARGKR	VQFN	RGK	64	2500	367.0	367.0	38.0
CC3220SM2ARGKT	VQFN	RGK	64	250	210.0	185.0	35.0

**RGK 64**

**GENERIC PACKAGE VIEW**

**VQFN - 1 mm max height**

PLASTIC QUAD FLATPACK - NO LEAD

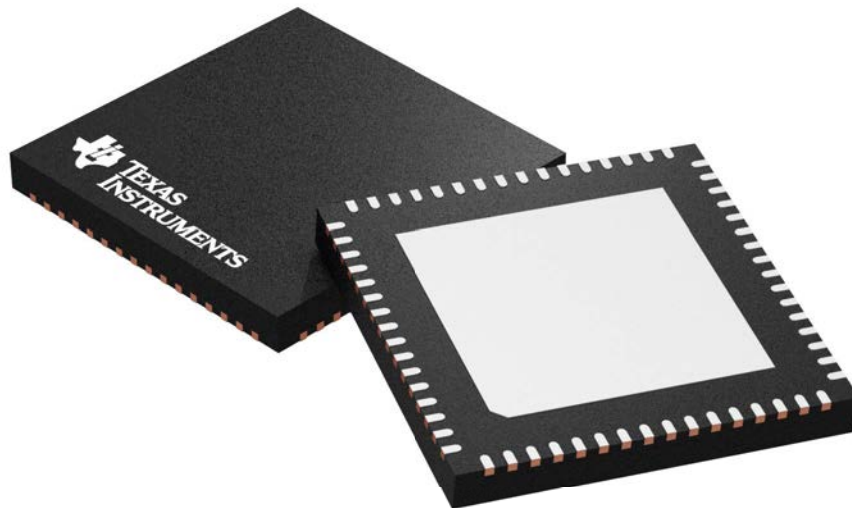

Images above are just a representation of the package family, actual package may vary.  
Refer to the product data sheet for package details.

4211520/D



# EXAMPLE BOARD LAYOUT

**RGK0064B**

**VQFN - 1 mm max height**

PLASTIC QUAD FLATPACK - NO LEAD

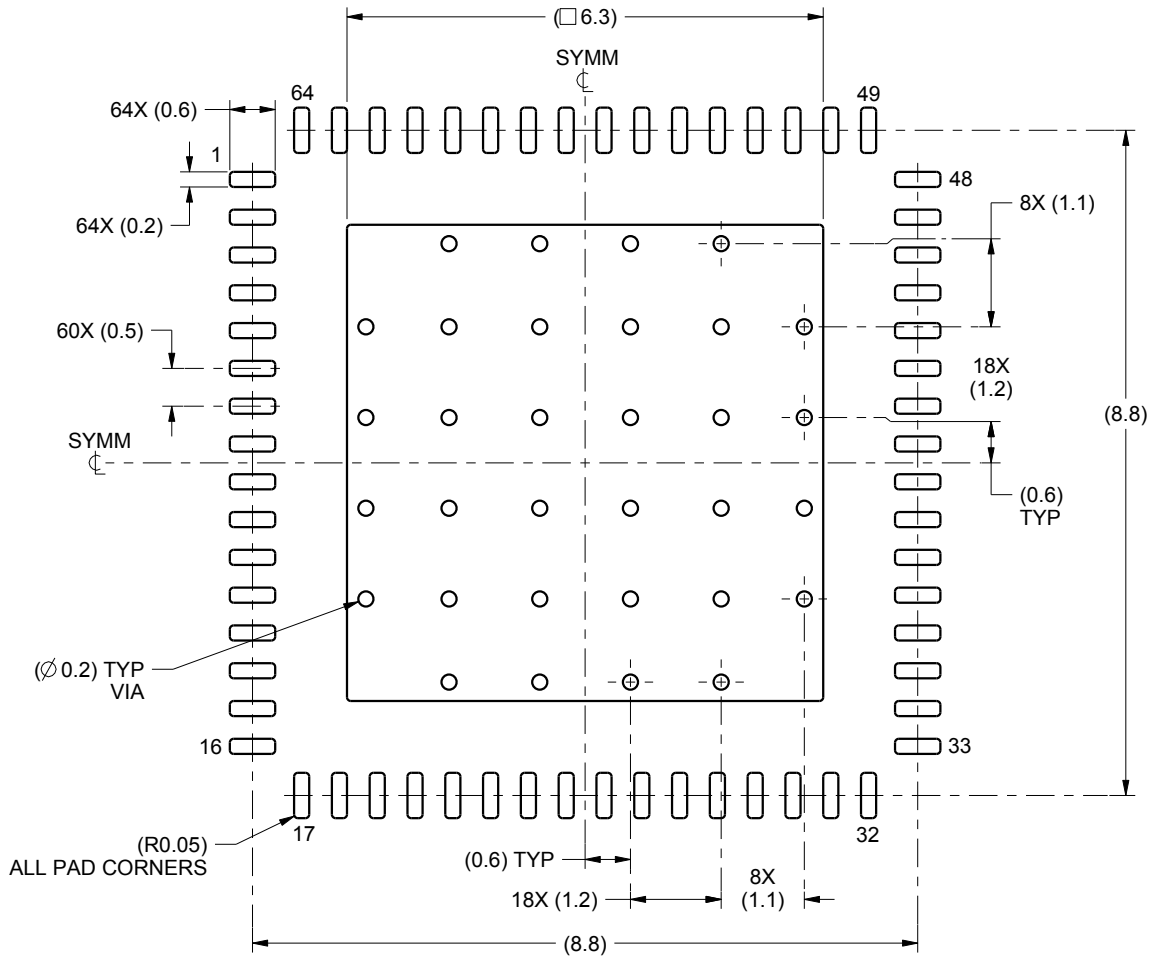

**LAND PATTERN EXAMPLE**  
SCALE:10X

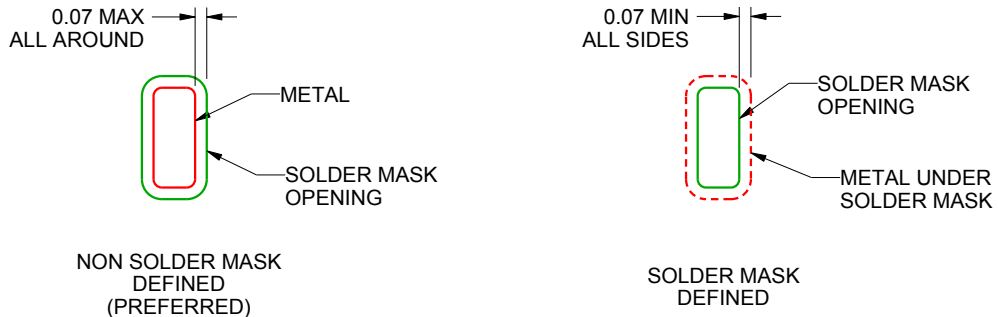

**SOLDER MASK DETAILS**

4222201/A 10/2015

NOTES: (continued)

4. This package is designed to be soldered to a thermal pad on the board. For more information, see Texas Instruments literature number SLUA271 ([www.ti.com/lit/slue271](http://www.ti.com/lit/slue271)).

# EXAMPLE STENCIL DESIGN

RGK0064B

VQFN - 1 mm max height

PLASTIC QUAD FLATPACK - NO LEAD

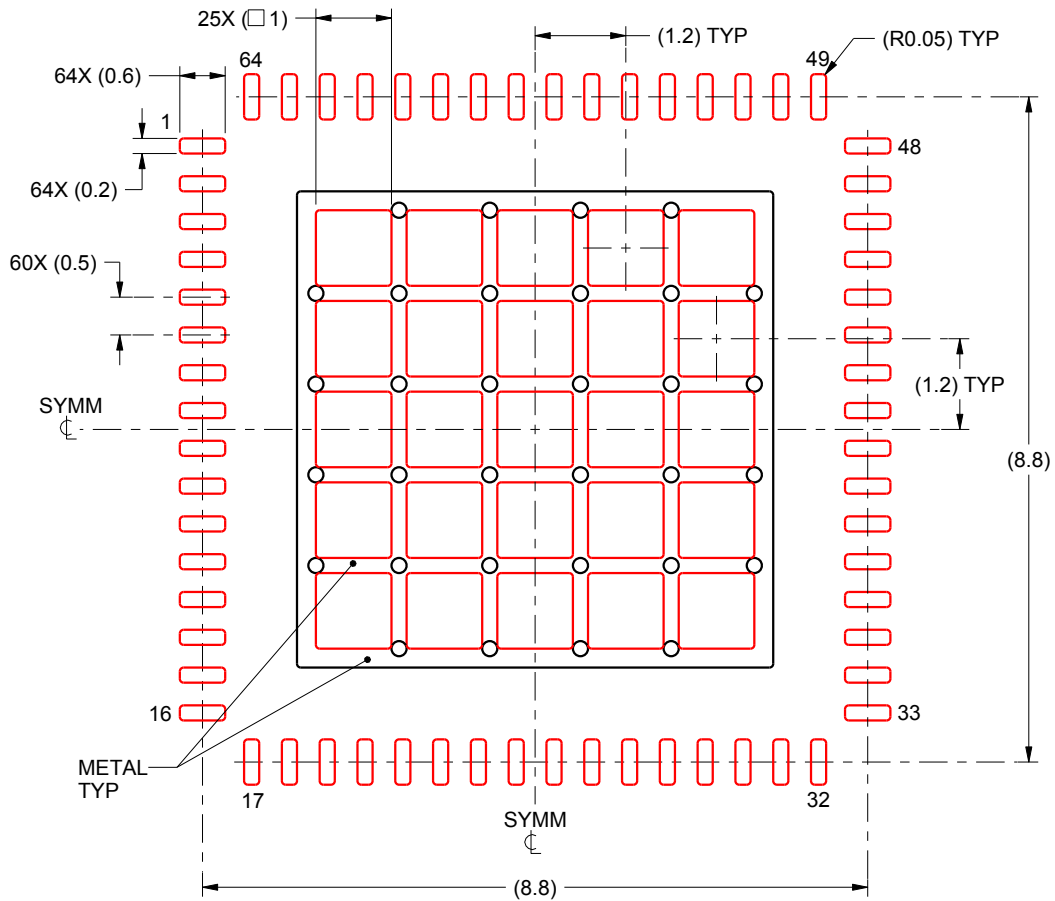

**SOLDER PASTE EXAMPLE**  
BASED ON 0.1 mm THICK STENCIL  
EXPOSED PAD  
67% PRINTED SOLDER COVERAGE BY AREA  
SCALE:10X

4222201/A 10/2015

NOTES: (continued)

5. Laser cutting apertures with trapezoidal walls and rounded corners may offer better paste release. IPC-7525 may have alternate design recommendations.

## IMPORTANT NOTICE

Texas Instruments Incorporated (TI) reserves the right to make corrections, enhancements, improvements and other changes to its semiconductor products and services per JESD46, latest issue, and to discontinue any product or service per JESD48, latest issue. Buyers should obtain the latest relevant information before placing orders and should verify that such information is current and complete.

TI's published terms of sale for semiconductor products (<http://www.ti.com/sc/docs/stdterms.htm>) apply to the sale of packaged integrated circuit products that TI has qualified and released to market. Additional terms may apply to the use or sale of other types of TI products and services.

Reproduction of significant portions of TI information in TI data sheets is permissible only if reproduction is without alteration and is accompanied by all associated warranties, conditions, limitations, and notices. TI is not responsible or liable for such reproduced documentation. Information of third parties may be subject to additional restrictions. Resale of TI products or services with statements different from or beyond the parameters stated by TI for that product or service voids all express and any implied warranties for the associated TI product or service and is an unfair and deceptive business practice. TI is not responsible or liable for any such statements.

Buyers and others who are developing systems that incorporate TI products (collectively, "Designers") understand and agree that Designers remain responsible for using their independent analysis, evaluation and judgment in designing their applications and that Designers have full and exclusive responsibility to assure the safety of Designers' applications and compliance of their applications (and of all TI products used in or for Designers' applications) with all applicable regulations, laws and other applicable requirements. Designer represents that, with respect to their applications, Designer has all the necessary expertise to create and implement safeguards that (1) anticipate dangerous consequences of failures, (2) monitor failures and their consequences, and (3) lessen the likelihood of failures that might cause harm and take appropriate actions. Designer agrees that prior to using or distributing any applications that include TI products, Designer will thoroughly test such applications and the functionality of such TI products as used in such applications.

TI's provision of technical, application or other design advice, quality characterization, reliability data or other services or information, including, but not limited to, reference designs and materials relating to evaluation modules, (collectively, "TI Resources") are intended to assist designers who are developing applications that incorporate TI products; by downloading, accessing or using TI Resources in any way, Designer (individually or, if Designer is acting on behalf of a company, Designer's company) agrees to use any particular TI Resource solely for this purpose and subject to the terms of this Notice.

TI's provision of TI Resources does not expand or otherwise alter TI's applicable published warranties or warranty disclaimers for TI products, and no additional obligations or liabilities arise from TI providing such TI Resources. TI reserves the right to make corrections, enhancements, improvements and other changes to its TI Resources. TI has not conducted any testing other than that specifically described in the published documentation for a particular TI Resource.

Designer is authorized to use, copy and modify any individual TI Resource only in connection with the development of applications that include the TI product(s) identified in such TI Resource. NO OTHER LICENSE, EXPRESS OR IMPLIED, BY ESTOPPEL OR OTHERWISE TO ANY OTHER TI INTELLECTUAL PROPERTY RIGHT, AND NO LICENSE TO ANY TECHNOLOGY OR INTELLECTUAL PROPERTY RIGHT OF TI OR ANY THIRD PARTY IS GRANTED HEREIN, including but not limited to any patent right, copyright, mask work right, or other intellectual property right relating to any combination, machine, or process in which TI products or services are used. Information regarding or referencing third-party products or services does not constitute a license to use such products or services, or a warranty or endorsement thereof. Use of TI Resources may require a license from a third party under the patents or other intellectual property of the third party, or a license from TI under the patents or other intellectual property of TI.

TI RESOURCES ARE PROVIDED "AS IS" AND WITH ALL FAULTS. TI DISCLAIMS ALL OTHER WARRANTIES OR REPRESENTATIONS, EXPRESS OR IMPLIED, REGARDING RESOURCES OR USE THEREOF, INCLUDING BUT NOT LIMITED TO ACCURACY OR COMPLETENESS, TITLE, ANY EPIDEMIC FAILURE WARRANTY AND ANY IMPLIED WARRANTIES OF MERCHANTABILITY, FITNESS FOR A PARTICULAR PURPOSE, AND NON-INFRINGEMENT OF ANY THIRD PARTY INTELLECTUAL PROPERTY RIGHTS. TI SHALL NOT BE LIABLE FOR AND SHALL NOT DEFEND OR INDEMNIFY DESIGNER AGAINST ANY CLAIM, INCLUDING BUT NOT LIMITED TO ANY INFRINGEMENT CLAIM THAT RELATES TO OR IS BASED ON ANY COMBINATION OF PRODUCTS EVEN IF DESCRIBED IN TI RESOURCES OR OTHERWISE. IN NO EVENT SHALL TI BE LIABLE FOR ANY ACTUAL, DIRECT, SPECIAL, COLLATERAL, INDIRECT, PUNITIVE, INCIDENTAL, CONSEQUENTIAL OR EXEMPLARY DAMAGES IN CONNECTION WITH OR ARISING OUT OF TI RESOURCES OR USE THEREOF, AND REGARDLESS OF WHETHER TI HAS BEEN ADVISED OF THE POSSIBILITY OF SUCH DAMAGES.

Unless TI has explicitly designated an individual product as meeting the requirements of a particular industry standard (e.g., ISO/TS 16949 and ISO 26262), TI is not responsible for any failure to meet such industry standard requirements.

Where TI specifically promotes products as facilitating functional safety or as compliant with industry functional safety standards, such products are intended to help enable customers to design and create their own applications that meet applicable functional safety standards and requirements. Using products in an application does not by itself establish any safety features in the application. Designers must ensure compliance with safety-related requirements and standards applicable to their applications. Designer may not use any TI products in life-critical medical equipment unless authorized officers of the parties have executed a special contract specifically governing such use. Life-critical medical equipment is medical equipment where failure of such equipment would cause serious bodily injury or death (e.g., life support, pacemakers, defibrillators, heart pumps, neurostimulators, and implantables). Such equipment includes, without limitation, all medical devices identified by the U.S. Food and Drug Administration as Class III devices and equivalent classifications outside the U.S.

TI may expressly designate certain products as completing a particular qualification (e.g., Q100, Military Grade, or Enhanced Product). Designers agree that it has the necessary expertise to select the product with the appropriate qualification designation for their applications and that proper product selection is at Designers' own risk. Designers are solely responsible for compliance with all legal and regulatory requirements in connection with such selection.

Designer will fully indemnify TI and its representatives against any damages, costs, losses, and/or liabilities arising out of Designer's non-compliance with the terms and provisions of this Notice.